

Wirewound Inductors

Low-Profile Inductors

Power Inductors

► Preview

Token's Low DCR Low-Profile Power Inductors fit into to more portable applications. Like many components in the industry, power wirewound inductors are being impacted by the trend toward smaller electronic devices with enhanced functionality requiring increased density of components on the board. Token introduces low-profile, high-current inductor in case size. The TPSH series offers designers a high-current solution using a larger part, without exceeding a profile of 1.2 mm on either side of the PC board.



The miniaturization of battery-powered devices also requires more compact circuit-board designs, and therefore smaller but more-effective inductor designs. Token (TPSH) offers an inductance range from 1.0 μH to 1000.0 μH , DCR from 0.009 Ω to 19.110 Ω , and IDC from 0.047A to 4.70A.

The (TPSH) inductor serves as a high-performing, space-saving and power-saving solution for low-profile, high-current power supplies and point of load (POL) converters; distributed power systems; voltage regulator module (VRM) and DC-to-DC converter applications in end products including next-generation mobile devices; notebooks, desktop computers, personal multimedia devices, automotive systems, servers, graphic cards, portable gaming devices, and personal navigation systems; and field-programmable gate arrays (FPGAs).

This wire-wound inductor handles high transient current spikes without hard saturation. Packaged in an RoHS-compliant, 100 % lead (Pb)-free shielded, composite construction that reduces buzz noise to ultra-low levels, the new device is specified for an operating temperature range of -25°C to +125°C, with high resistance to mechanical shock, thermal shock, moisture, and vibration.

Custom parts are available on request. Token will also produce devices outside these specifications to meet specific customer requirements, please contact our sales for more information.

Features :

- Various high power wire-wound inductors are superior to be high saturation for surface mounting.

Applications :

- DC/DC converters, power supply for VCRS.
- OA equipment, digital camera, LCD, television set.
- Notebook, portable communication equipments.

▶ Dimensions & Configurations (TPSH)

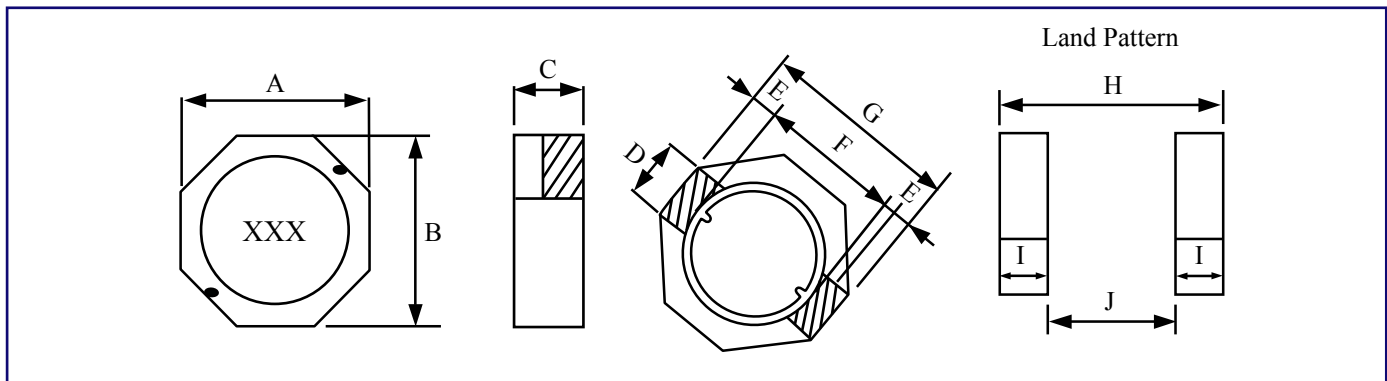

Type	A	B	C(Max)	D(typ.)	E(typ.)	F(typ.)	G	H(typ.)	I(typ.)	J(typ.)
TPSH0301	3.85 ± 0.30	3.85 ± 0.30	1.30	1.60	0.50	3.20	3.9 ± 0.2	4.55	1.90	3.0
TPSH0302	3.85 ± 0.30	3.85 ± 0.30	2.0	1.60	0.50	3.20	3.9 ± 0.2	4.55	1.90	3.0
TPSH0303	3.85 ± 0.30	3.85 ± 0.30	3.0	1.60	0.50	3.20	3.9 ± 0.2	4.55	1.90	3.0
TPSH0501	5.3Max	5.3Max	1.30	1.60	0.50	4.20	5.4 ± 0.4	5.7	1.90	3.9
TPSH0502	5.3Max	5.3Max	2.0	1.60	0.50	4.20	5.4 ± 0.4	5.7	1.90	3.9
TPSH0503	5.3Max	5.3Max	3.0	1.60	0.50	4.20	5.4 ± 0.4	5.7	1.90	3.9
TPSH0601	5.9 ± 0.2	5.9 ± 0.2	1.2	2.40	0.80	3.20	6.4 ± 0.3	6.5	2.70	4.4
TPSH06015	5.9 ± 0.2	5.9 ± 0.2	1.5	2.40	0.80	3.20	6.4 ± 0.3	6.5	2.70	4.4
TPSH0602	5.9 ± 0.2	5.9 ± 0.2	2.0	2.40	0.80	3.20	6.4 ± 0.3	6.5	2.70	4.4
TPSH06025	5.9 ± 0.2	5.9 ± 0.2	2.5	2.40	0.80	3.20	6.4 ± 0.3	6.5	2.70	4.4
TPSH0603	5.9 ± 0.2	5.9 ± 0.2	3.0	2.40	0.80	3.20	6.4 ± 0.3	6.5	2.70	4.4

Note : Design as Customer's Requested Specifications.

▶ **Electrical Characteristics (TPSH0301)**

Part Number	Inductance (μH)	Test Freq. (KHz)	DCR (Ω) (max)	IDC (A) (max)
TPSH0301 - 1R0N	1.0	100	0.060	1.60
TPSH0301 - 1R2N	1.2	100	0.065	1.40
TPSH0301 - 1R5N	1.5	100	0.077	1.24
TPSH0301 - 1R8N	1.8	100	0.093	1.22
TPSH0301 - 2R2N	2.2	100	0.125	1.20
TPSH0301 - 3R3N	3.3	100	0.187	0.89
TPSH0301 - 3R9N	3.9	100	0.220	0.78
TPSH0301 - 4R7N	4.7	100	0.240	0.71
TPSH0301 - 5R6N	5.6	100	0.320	0.62
TPSH0301 - 6R8N	6.8	100	0.350	0.57
TPSH0301 - 8R2N	8.2	100	0.470	0.52
TPSH0301 - 100M	10	100	0.570	0.47
TPSH0301 - 120M	12	100	0.750	0.43
TPSH0301 - 150M	15	100	0.810	0.38
TPSH0301 - 180M	18	100	1.060	0.35
TPSH0301 - 220M	22	100	1.150	0.32
TPSH0301 - 270M	27	100	1.670	0.29
TPSH0301 - 330M	33	100	1.840	0.28
TPSH0301 - 390M	39	100	2.310	0.25
TPSH0301 - 470M	47	100	2.630	0.22
TPSH0301 - 560M	56	100	2.860	0.20
TPSH0301 - 680M	68	100	3.940	0.18
TPSH0301 - 820M	82	100	4.900	0.16
TPSH0301 - 101M	100	1	5.740	0.14
TPSH0301 - 121M	120	1	7.310	0.13
TPSH0301 - 151M	150	1	9.080	0.12

Note: 1.0 ~ 82 μH Test Freq.: 100KHz/0.25V; 100 ~ 150 μH Test Freq.: 1KHz / 0.3V.

IDC: The current when the inductance becomes 35% lower than its nominal value.($t_a=20^\circ\text{C}$).

Electrical Characteristics (TPSH0302)

Part Number	Inductance (μH)	Test Freq. (KHz)	DCR (Ω) (max)	IDC (A) (max)
TPSH0302 - 1R0N	1.0	100	0.030	1.80
TPSH0302 - 1R2N	1.2	100	0.083	1.70
TPSH0302 - 1R5N	1.5	100	0.052	1.60
TPSH0302 - 1R8N	1.8	100	0.056	1.55
TPSH0302 - 2R2N	2.2	100	0.058	1.50
TPSH0302 - 2R7N	2.7	100	0.060	0.15
TPSH0302 - 3R3N	3.3	100	0.061	1.30
TPSH0302 - 4R7N	4.7	100	0.146	1.10
TPSH0302 - 5R6N	5.6	100	0.176	0.95
TPSH0302 - 6R8N	6.8	100	0.238	0.90
TPSH0302 - 8R2N	8.2	100	0.272	0.80
TPSH0302 - 100M	10	100	0.30	0.70
TPSH0302 - 120M	12	100	0.47	0.61
TPSH0302 - 150M	15	100	0.59	0.52
TPSH0302 - 220M	22	100	0.63	0.44
TPSH0302 - 330M	33	100	1.07	0.43
TPSH0302 - 470M	47	100	1.31	0.34
TPSH0302 - 680M	68	100	2.61	0.25
TPSH0302 - 820M	82	100	2.95	0.20
TPSH0302 - 101M	100	1	3.25	0.19
TPSH0302 - 151M	150	1	3.55	0.12
TPSH0302 - 331M	330	1	7.28	0.08
TPSH0302 - 681M	680	1	13.37	0.07

Note: 1.0 ~ 82 μH Test Freq.: 100KHz/0.25V; 100 ~ 680 μH Test Freq.: 1KHz / 0.3V.

IDC: The current when the inductance becomes 35% lower than its nominal value.($t_a=20^\circ\text{C}$).TPSH0501 -

▶ **Electrical Characteristics (TPSH0303)**

Part Number	Inductance (μ H)	Test Freq. (KHz)	DCR (Ω) (max)	IDC (A) (max)
TPSH0303 - 1R0N	1.0	100	0.009	1.90
TPSH0303 - 1R2N	1.2	100	0.010	1.75
TPSH0303 - 1R5N	1.5	100	0.013	1.45
TPSH0303 - 2R2N	2.2	100	0.017	1.15
TPSH0303 - 2R7N	2.7	100	0.020	1.00
TPSH0303 - 3R3N	3.3	100	0.024	0.96
TPSH0303 - 3R9N	3.9	100	0.033	0.87
TPSH0303 - 4R7N	4.7	100	0.039	0.78
TPSH0303 - 5R6N	5.6	100	0.044	0.74
TPSH0303 - 6R8N	6.8	100	0.051	0.68
TPSH0303 - 8R2N	8.2	100	0.065	0.57
TPSH0303 - 100M	10	100	0.092	0.43
TPSH0303 - 150M	15	100	0.113	0.33
TPSH0303 - 180M	18	100	0.125	0.30
TPSH0303 - 220M	22	100	0.146	0.28
TPSH0303 - 270M	27	100	0.176	0.26
TPSH0303 - 330M	33	100	0.214	0.23
TPSH0303 - 390M	39	100	0.225	0.21
TPSH0303 - 470M	47	100	0.304	0.19
TPSH0303 - 560M	56	100	0.324	0.17
TPSH0303 - 680M	68	100	0.472	0.15
TPSH0303 - 820M	82	100	0.539	0.14
TPSH0303 - 101M	100	1	0.608	0.128
TPSH0303 - 121M	120	1	0.757	0.116
TPSH0303 - 151M	150	1	0.882	0.106
TPSH0303 - 181M	180	1	1.130	0.095
TPSH0303 - 221M	220	1	1.269	0.087
TPSH0303 - 271M	270	1	1.570	0.080
TPSH0303 - 331M	330	1	1.930	0.078
TPSH0303 - 391M	390	1	2.360	0.073
TPSH0303 - 471M	470	1	2.770	0.065
TPSH0303 - 561M	560	1	3.520	0.056
TPSH0303 - 681M	680	1	4.250	0.056
TPSH0303 - 821M	820	1	5.830	0.050
TPSH0303 - 102M	1000	1	6.260	0.047

Note: 1.0 ~ 82 μ H Test Freq.: 100KHz/0.25V; 100 ~ 1000 μ H Test Freq.: 1KHz / 0.3V.

IDC: The current when the inductance becomes 35% lower than its nominal value.(ta=20°C).

Electrical Characteristics (TPSH0501)

Part Number	Inductance (μH)	Test Freq. (KHz)	DCR (Ω) (max)	IDC (A) (max)
TPSH0501 - 1R0N	1.0	100	0.044	1.620
TPSH0501 - 1R2N	1.2	100	0.045	1.610
TPSH0501 - 2R0N	2.0	100	0.062	1.300
TPSH0501 - 2R2N	2.2	100	0.067	1.230
TPSH0501 - 4R7N	4.7	100	0.120	0.780
TPSH0501 - 5R6N	5.6	100	0.140	0.740
TPSH0501 - 6R8N	6.8	100	0.170	0.620
TPSH0501 - 8R2N	8.2	100	0.230	0.600
TPSH0501 - 100M	10	100	0.238	0.560
TPSH0501 - 150M	15	100	0.402	0.420
TPSH0501 - 220M	22	100	0.550	0.380
TPSH0501 - 330M	33	100	0.780	0.310
TPSH0501 - 470M	47	100	1.140	0.270
TPSH0501 - 680M	68	100	1.530	0.200
TPSH0501 - 101M	100	1	2.130	0.160
TPSH0501 - 121M	120	1	2.370	0.150
TPSH0501 - 151M	150	1	3.390	0.130
TPSH0501 - 181M	180	1	4.120	0.120
TPSH0501 - 221M	220	1	4.510	0.110
TPSH0501 - 271M	270	1	5.620	0.100
TPSH0501 - 331M	330	1	6.750	0.098
TPSH0501 - 391M	390	1	11.23	0.084
TPSH0501 - 471M	470	1	12.38	0.080

Note: 1.0 ~ 82 μH Test Freq.: 100KHz/0.25V; 100 ~ 470 μH Test Freq.: 1KHz / 0.3V.

IDC: The current when the inductance becomes 35% lower than its nominal value.($t_a=20^\circ\text{C}$).

▶ **Electrical Characteristics (TPSH0502)**

Part Number	Inductance (μH)	Test Freq. (KHz)	DCR (Ω) (max)	IDC (A) (max)
TPSH0502 - 1R2N	1.2	100	0.044	2.150
TPSH0502 - 2R0N	2.0	100	0.046	1.900
TPSH0502 - 2R2N	2.2	100	0.059	1.630
TPSH0502 - 3R3N	3.3	100	0.062	1.500
TPSH0502 - 4R7N	4.7	100	0.087	1.140
TPSH0502 - 6R8N	6.8	100	0.105	0.950
TPSH0502 - 8R2N	8.2	100	0.139	0.900
TPSH0502 - 100M	10	100	0.150	0.760
TPSH0502 - 150M	15	100	0.210	0.630
TPSH0502 - 220M	22	100	0.275	0.560
TPSH0502 - 330M	33	100	0.455	0.440
TPSH0502 - 470M	47	100	0.730	0.350
TPSH0502 - 680M	68	100	0.935	0.300
TPSH0502 - 101M	100	1	1.500	0.230
TPSH0502 - 121M	120	1	1.910	0.220
TPSH0502 - 151M	150	1	2.680	0.210
TPSH0502 - 181M	180	1	3.040	0.200
TPSH0502 - 221M	220	1	3.520	0.195
TPSH0502 - 271M	270	1	4.380	0.193
TPSH0502 - 331M	330	1	5.560	0.190
TPSH0502 - 471M	470	1	7.820	0.180
TPSH0502 - 561M	560	1	9.79	0.170

Note: 1.0 ~ 82μH Test Freq.: 100KHz/0.25V; 100 ~ 560μH Test Freq.: 1KHz / 0.3V.

IDC: The current when the inductance becomes 35% lower than its nominal value.(ta=20°C).

Electrical Characteristics (TPSH0503)

Part Number	Inductance (μH)	Test Freq. (KHz)	DCR (Ω) (max)	IDC (A) (max)
TPSH0503 - 1R0N	1.0	100	0.015	4.00
TPSH0503 - 1R2N	1.2	100	0.022	3.80
TPSH0503 - 2R0N	2.0	100	0.027	2.92
TPSH0503 - 2R2N	2.2	100	0.029	2.41
TPSH0503 - 3R3N	3.3	100	0.034	2.36
TPSH0503 - 4R7N	4.7	100	0.045	1.87
TPSH0503 - 5R6N	5.6	100	0.052	1.60
TPSH0503 - 6R8N	6.8	100	0.068	1.51
TPSH0503 - 100M	10	100	0.090	1.33
TPSH0503 - 150M	15	100	0.142	1.05
TPSH0503 - 220M	22	100	0.208	0.86
TPSH0503 - 330M	33	100	0.257	0.72
TPSH0503 - 470M	47	100	0.352	0.62
TPSH0503 - 680M	68	100	0.525	0.51
TPSH0503 - 101M	100	1	0.80	0.43
TPSH0503 - 121M	120	1	0.85	0.34
TPSH0503 - 151M	150	1	1.10	0.26
TPSH0503 - 181M	180	1	1.19	0.24
TPSH0503 - 221M	220	1	1.53	0.20
TPSH0503 - 331M	330	1	2.03	0.19
TPSH0503 - 391M	390	1	3.00	0.16
TPSH0503 - 471M	470	1	3.50	0.15
TPSH0503 - 561M	560	1	3.08	0.14

Note: 1.0 ~ 82 μH Test Freq.: 100KHz/0.25V; 100 ~ 560 μH Test Freq.: 1KHz / 0.3V.

IDC: The current when the inductance becomes 35% lower than its nominal value.($t_a=20^\circ\text{C}$).

▶ **Electrical Characteristics (TPSH0601)**

Part Number	Inductance (μ H)	Test Freq. (KHz)	DCR (Ω) (max)	IDC (A) (max)
TPSH0601 - 1R0N	1.0	100	0.046	2.04
TPSH0601 - 1R5N	1.5	100	0.052	1.46
TPSH0601 - 2R0N	2.0	100	0.060	1.22
TPSH0601 - 2R2N	2.2	100	0.060	1.22
TPSH0601 - 2R7N	2.7	100	0.070	1.12
TPSH0601 - 3R3N	3.3	100	0.090	0.94
TPSH0601 - 3R9N	3.9	100	0.100	0.86
TPSH0601 - 4R7N	4.7	100	0.120	0.84
TPSH0601 - 5R6N	5.6	100	0.140	0.74
TPSH0601 - 6R8N	6.8	100	0.160	0.68
TPSH0601 - 8R2N	8.2	100	0.190	0.62
TPSH0601 - 100M	10	100	0.210	0.58
TPSH0601 - 120M	12	100	0.270	0.52
TPSH0601 - 150M	15	100	0.330	0.48
TPSH0601 - 180M	18	100	0.440	0.42
TPSH0601 - 220M	22	100	0.460	0.40
TPSH0601 - 270M	27	100	0.560	0.34
TPSH0601 - 330M	33	100	0.630	0.32
TPSH0601 - 390M	39	100	0.780	0.30
TPSH0601 - 470M	47	100	0.900	0.28
TPSH0601 - 560M	56	100	1.080	0.24
TPSH0601 - 680M	68	100	1.340	0.22
TPSH0601 - 820M	82	100	1.540	0.20
TPSH0601 - 101M	100	1	1.960	0.18
TPSH0601 - 121M	120	1	2.300	0.16
TPSH0601 - 151M	150	1	2.700	0.14
TPSH0601 - 181M	180	1	3.470	0.13
TPSH0601 - 221M	220	1	4.500	0.12
TPSH0601 - 271M	270	1	4.620	0.10
TPSH0601 - 331M	330	1	6.350	0.09
TPSH0601 - 391M	390	1	7.520	0.09
TPSH0601 - 471M	470	1	8.640	0.084
TPSH0601 - 561M	560	1	11.02	0.074

Note: 1.0 ~ 82 μ H Test Freq.: 100KHz/0.25V; 100 ~ 560 μ H Test Freq.: 1KHz / 0.3V.

IDC: The current when the inductance becomes 35% lower than its nominal value.(ta=20°C).

Electrical Characteristics (TPSH0602)

Part Number	Inductance (μH)	Test Freq. (KHz)	DCR (Ω) (max)	IDC (A) (max)
TPSH0602 - 1R0N	1.0	100	0.021	3.82
TPSH0602 - 1R2N	1.2	100	0.025	3.02
TPSH0602 - 1R8N	1.8	100	0.038	2.30
TPSH0602 - 2R2N	2.2	100	0.033	2.52
TPSH0602 - 3R3N	3.3	100	0.050	1.95
TPSH0602 - 3R9N	3.9	100	0.055	1.92
TPSH0602 - 4R7N	4.7	100	0.064	1.62
TPSH0602 - 5R6N	5.6	100	0.076	1.42
TPSH0602 - 6R8N	6.8	100	0.097	1.27
TPSH0602 - 8R2N	8.2	100	0.105	1.10
TPSH0602 - 100M	10	100	0.130	0.98
TPSH0602 - 120M	12	100	0.170	0.96
TPSH0602 - 150M	15	100	0.190	0.94
TPSH0602 - 180M	18	100	0.220	0.92
TPSH0602 - 220M	22	100	0.260	0.82
TPSH0602 - 270M	27	100	0.320	0.74
TPSH0602 - 330M	33	100	0.370	0.62
TPSH0602 - 390M	39	100	0.470	0.52
TPSH0602 - 470M	47	100	0.560	0.50
TPSH0602 - 560M	56	100	0.710	0.44
TPSH0602 - 680M	68	100	0.810	0.40
TPSH0602 - 820M	82	100	1.000	0.34
TPSH0602 - 101M	100	1	1.300	0.32
TPSH0602 - 121M	120	1	1.430	0.26
TPSH0602 - 151M	150	1	1.860	0.24
TPSH0602 - 181M	180	1	2.250	0.22
TPSH0602 - 221M	220	1	2.750	0.20
TPSH0602 - 271M	270	1	3.490	0.18
TPSH0602 - 331M	330	1	4.090	0.16
TPSH0602 - 391M	390	1	4.640	0.15
TPSH0602 - 471M	470	1	5.800	0.14
TPSH0602 - 561M	560	1	7.340	0.13
TPSH0602 - 681M	680	1	9.230	0.12
TPSH0602 - 821M	820	1	11.010	0.11
TPSH0602 - 102M	1000	1	12.580	0.10

Note: 1.0 ~ 82 μH Test Freq.: 100KHz/0.25V; 100 ~ 1000 μH Test Freq.: 1KHz / 0.3V.

IDC: The current when the inductance becomes 35% lower than its nominal value.($t_a=20^\circ\text{C}$).

▶ **Electrical Characteristics (TPSH0603)**

Part Number	Inductance (μH)	Test Freq. (KHz)	DCR (Ω) (max)	IDC (A) (max)
TPSH0603 - 1R0N	1.0	100	0.014	4.70
TPSH0603 - 1R2N	1.2	100	0.016	3.90
TPSH0603 - 1R8N	1.8	100	0.019	3.25
TPSH0603 - 2R2N	2.2	100	0.022	2.95
TPSH0603 - 3R3N	3.3	100	0.030	2.45
TPSH0603 - 3R9N	3.9	100	0.034	2.35
TPSH0603 - 4R7N	4.7	100	0.042	2.25
TPSH0603 - 5R6N	5.6	100	0.048	2.05
TPSH0603 - 6R8N	6.8	100	0.054	1.85
TPSH0603 - 8R2N	8.2	100	0.058	1.65
TPSH0603 - 100M	10	100	0.065	1.45
TPSH0603 - 120M	12	100	0.082	1.35
TPSH0603 - 150M	15	100	0.096	1.25
TPSH0603 - 180M	18	100	0.110	1.15
TPSH0603 - 220M	22	100	0.140	0.98
TPSH0603 - 270M	27	100	0.170	0.90
TPSH0603 - 330M	33	100	0.210	0.80
TPSH0603 - 390M	39	100	0.240	0.72
TPSH0603 - 470M	47	100	0.280	0.70
TPSH0603 - 560M	56	100	0.340	0.66
TPSH0603 - 680M	68	100	0.410	0.58
TPSH0603 - 820M	82	100	0.490	0.52
TPSH0603 - 101M	100	1	0.550	0.46
TPSH0603 - 121M	120	1	0.700	0.42
TPSH0603 - 151M	150	1	0.780	0.36
TPSH0603 - 181M	180	1	0.960	0.34
TPSH0603 - 221M	220	1	1.080	0.32
TPSH0603 - 271M	270	1	1.360	0.28
TPSH0603 - 331M	330	1	1.820	0.24
TPSH0603 - 391M	390	1	2.050	0.22
TPSH0603 - 471M	470	1	2.580	0.20
TPSH0603 - 561M	560	1	3.160	0.18
TPSH0603 - 681M	680	1	4.040	0.16
TPSH0603 - 821M	820	1	4.900	0.14
TPSH0603 - 102M	1000	1	6.000	0.13

Note: 1.0 ~ 82 μH Test Freq.: 100KHz/0.25V; 100 ~ 1000 μH Test Freq.: 1KHz / 0.3V.

IDC: The current when the inductance becomes 35% lower than its nominal value.($t_a=20^\circ\text{C}$).

Electrical Characteristics (TPSH06015)

Part Number	Inductance (μH)	Test Freq. (KHz)	DCR (Ω) (max)	IDC (A) (max)
TPSH06015 - 1R0N	1.0	100	0.028	2.62
TPSH06015 - 1R5N	1.5	100	0.038	2.08
TPSH06015 - 1R8N	1.8	100	0.042	1.98
TPSH06015 - 2R2N	2.2	100	0.048	1.98
TPSH06015 - 2R7N	2.7	100	0.062	1.72
TPSH06015 - 3R3N	3.3	100	0.070	1.48
TPSH06015 - 3R9N	3.9	100	0.092	1.30
TPSH06015 - 4R7N	4.7	100	0.100	1.58
TPSH06015 - 5R6N	5.6	100	0.110	1.14
TPSH06015 - 6R8N	6.8	100	0.140	1.10
TPSH06015 - 8R2N	8.2	100	0.160	0.98
TPSH06015 - 100M	10	100	0.180	0.82
TPSH06015 - 120M	12	100	0.210	0.796
TPSH06015 - 150M	15	100	0.250	0.70
TPSH06015 - 180M	18	100	0.310	0.64
TPSH06015 - 220M	22	100	0.380	0.56
TPSH06015 - 270M	27	100	0.490	0.52
TPSH06015 - 330M	33	100	0.560	0.46
TPSH06015 - 390M	39	100	0.710	0.42
TPSH06015 - 470M	47	100	0.840	0.38
TPSH06015 - 560M	56	100	0.930	0.34
TPSH06015 - 680M	68	100	1.080	0.32
TPSH06015 - 820M	82	100	1.380	0.30
TPSH06015 - 101M	100	1	1.660	0.26
TPSH06015 - 121M	120	1	2.050	0.24
TPSH06015 - 151M	150	1	2.650	0.20
TPSH06015 - 181M	180	1	3.010	0.18
TPSH06015 - 221M	220	1	3.670	0.16
TPSH06015 - 271M	270	1	4.670	0.140
TPSH06015 - 331M	330	1	6.080	0.120
TPSH06015 - 391M	390	1	7.430	0.100
TPSH06015 - 471M	470	1	8.570	0.098
TPSH06015 - 561M	560	1	9.840	0.096
TPSH06015 - 681M	680	1	12.950	0.094
TPSH06015 - 821M	820	1	16.610	0.092
TPSH06015 - 102M	1000	1	19.110	0.090

Note: 1.0 ~ 82 μH Test Freq.: 100KHz/0.25V; 100 ~ 1000 μH Test Freq.: 1KHz / 0.3V.

IDC: The current when the inductance becomes 35% lower than its nominal value.($t_a=20^\circ\text{C}$).

▶ Electrical Characteristics (TPSH06025)

Part Number	Inductance (μH)	Test Freq. (KHz)	DCR (Ω) (max)	IDC (A) (max)
TPSH06025 - 1R0N	1.0	100	0.019	4.20
TPSH06025 - 1R5N	1.5	100	0.023	3.82
TPSH06025 - 1R8N	1.8	100	0.025	3.10
TPSH06025 - 2R2N	2.2	100	0.027	2.53
TPSH06025 - 3R3N	3.3	100	0.034	2.22
TPSH06025 - 3R9N	3.9	100	0.040	2.00
TPSH06025 - 4R7N	4.7	100	0.044	1.92
TPSH06025 - 5R6N	5.6	100	0.050	1.68
TPSH06025 - 6R8N	6.8	100	0.059	1.54
TPSH06025 - 8R2N	8.2	100	0.070	1.46
TPSH06025 - 100M	10	100	0.095	1.22
TPSH06025 - 120M	12	100	0.108	1.08
TPSH06025 - 150M	15	100	0.116	0.96
TPSH06025 - 180M	18	100	0.150	0.85
TPSH06025 - 220M	22	100	0.187	0.82
TPSH06025 - 270M	27	100	0.210	0.74
TPSH06025 - 330M	33	100	0.262	0.38
TPSH06025 - 390M	39	100	0.312	0.64
TPSH06025 - 470M	47	100	0.352	0.98
TPSH06025 - 560M	56	100	0.392	0.52
TPSH06025 - 680M	68	100	0.468	0.46
TPSH06025 - 820M	82	100	0.640	0.44
TPSH06025 - 101M	100	1	0.773	0.36
TPSH06025 - 121M	120	1	0.882	0.32
TPSH06025 - 151M	150	1	1.020	0.28
TPSH06025 - 181M	180	1	1.382	0.24
TPSH06025 - 221M	220	1	1.690	0.22
TPSH06025 - 271M	270	1	1.900	0.20
TPSH06025 - 331M	330	1	2.420	0.18
TPSH06025 - 391M	390	1	2.780	0.16
TPSH06025 - 471M	470	1	3.460	0.15
TPSH06025 - 561M	560	1	4.020	0.14
TPSH06025 - 681M	680	1	4.960	0.13
TPSH06025 - 821M	820	1	6.280	0.12
TPSH06025 - 102M	1000	1	7.820	0.10

Note: 1.0 ~ 82 μH Test Freq.: 100KHz/0.25V; 100 ~ 1000 μH Test Freq.: 1KHz / 0.3V.

IDC: The current when the inductance becomes 35% lower than its nominal value.($t_a=20^\circ\text{C}$).

▶ How to Order

TPSH0301

❶

1R0

❷

M

❸

- ❶ Part Number: TPSH0301, TPSH0302, TPSH0303
 TPSH0501, TPSH0502, TPSH0503
 TPSH0601, TPSH0602, TPSH0603
 TPSH06015, TPSH06025

❷ Inductance

Code	Inductance
R78	0.78 μ H
1R0	1.00 μ H
120	12.00 μ H
220	22.00 μ H

❸ Tolerance

Code	Tolerance
M	20%
N	30%

[Back to 1st Page - Wirewound Inductors / Low-Profile Inductors \(TTPSRH-3D/4D/5D/6D\)](#)