

Version:
December 1, 2022



(TRWL)
**Wire Wound Chip
Ceramic Inductor**

Web: www.token.com.tw

Email: rfq@token.com.tw

Token Electronics Industry Co., Ltd.

**Taiwan: No.137, Sec. 1, Zhongxing Rd., Wugu District,
New Taipei City, Taiwan. 248012
Tel: +886 2981 0109 Fax: +886 2988 7487**

**China: 17P, Nanyuan Maple Leaf Bldg., Nanshan Ave.,
Nanshan Dist., Shenzhen, Guangdong, China. 518054
Tel: +86 755 26055363**



▶ Product Introduction**Token Wire wound Ceramic Inductor Simplifies Power Management Issues.****Features :**

- Tighter Tolerance of $\pm 2\%$.
- Fully Automated Assembly.
- Smaller Size of 0402 (1005).
- Miniature ultra-compact size.
- High SRFs, exceptional Q values.
- Low profile, High Current are Available.

Applications :

- Remote Control, Security System, Wireless PDA.
- TCWLL, Wireless LAN / Mouse / Keyboard / Earphone.
- Cellular Phone (CDMA/GSM/PHS), Cordless Phone (DECT/CT1CT2).
- CATV Filter, VCO, RF Module & Other Wireless Products.
- Tuner, Set Top Box, Base Station, Repeater GPS Receiver.
- USB 2.0, IEEE 1394, Cable Modem / XDSL Tuner.

Token (TRWL) series is a wire wound and ceramic technology that offers the highest usable frequency range, highest current carrying capability, and the best Q factor of the three technologies. The combination of these three advantages ensures that design engineers will have the right product for many more high frequency applications than most competitors.

High frequency inductors are specifically used for their frequency dependent properties. Depending on the technology, size and inductance value, the inductor will pass a certain desired range of frequencies, but will block or attenuate frequencies above the desired range. This eliminates high frequency noise or interference from communications signals.

The Construction of Token (TRWL) open-type series chip wire wound ceramic inductors are designed to provide high SRFs. The full (TRWL) series conform to the RoHS directive and Lead-free. Customized designs and tighter tolerances are available on request.

Primarily, Token (TRWL) series as power inductors required by power supply circuits of multifunctional and small mobile phones must be small in size and low in height. These products must exhibit performance that is commensurate with the high power conversion efficiency of power supply circuits. Power supply circuits must also exhibit resistance to noise in the power supply state. All performance requirements of this component is expected based on the wire-wound inductors manufactured by Token.

Application of specific designs also available including different inductance values and Q specifications adjusted to frequency requirements. The (TRWL) series is supplied in tape and reel packaging ready for use with automated assembly processes. Contact us with your specific needs. For more information, please link to Token official website "[RF Inductors](http://www.token.com.tw)".



► Configurations & Dimensions

Configurations & Dimensions (Unit: mm) (TRWL)

Series	A Max.	B Max.	C Max.	D Ref.	E	F	G	H	I	J
Standard										
TRWL02 (EIA 0402)	1.27	0.76	0.61	0.15	0.51	0.23	0.56	0.66	0.50	0.46
TRWL03 (EIA 0603)	1.80	1.12	1.02	0.38	0.76	0.33	0.86	1.02	0.64	0.64
TRWL05 (EIA 0805)	2.29	1.73	1.52	0.51	1.27	0.44	1.02	1.78	1.02	0.76
TRWL06 (EIA 1206)	3.56	2.16	1.52	0.50	1.20	0.50	2.20	1.93	1.02	1.78
TRWL08 (EIA 1008)	2.92	2.79	2.03	0.65	2.03	0.51	1.52	2.54	1.02	1.27
Low Profile										
TRWL05 (EIA 0805)	2.29	1.73	1.03	0.51	1.27	0.44	1.02	1.78	1.02	0.76
TRWL08 (EIA 1008)	2.92	2.79	1.40	0.65	2.03	0.51	1.52	2.54	1.02	1.27
High Current / High Q										
TRWL03 (EIA 0603)	1.80	1.12	1.02	0.38	0.76	0.33	0.86	1.02	0.64	0.64
TRWL05 (EIA 0805)	2.29	1.73	1.52	0.51	1.27	0.44	1.02	1.78	1.02	0.76
TRWL08 (EIA 1008)	2.92	2.79	2.03	0.65	2.03	0.51	1.52	2.54	1.02	1.27

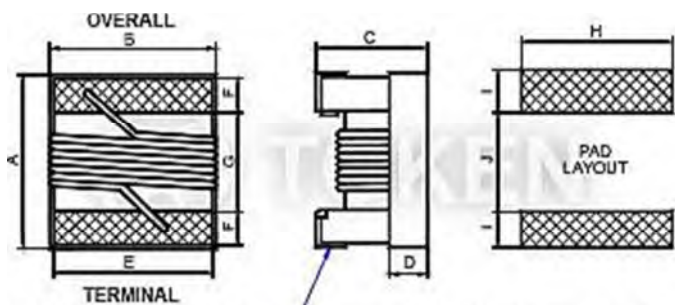

TERMINAL
TERMINAL WARP AROUND: Approx. 0.007" / 0.18mm Both Ends

Reel Dimensions

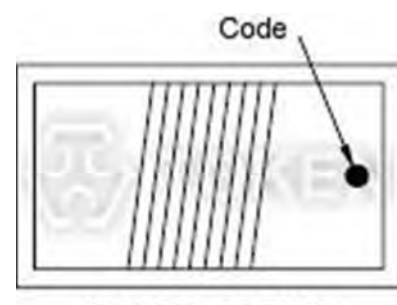

COLOR CODING

Tape Packing Dimensions

● **Note: Color Coding:**

0603 / 0805 / 1206 / 1008 Series (0402 Series is No Color Coding)

Because of small sizes, these parts are marked with a single color dot. The inductance value represented by the dot is shown on the data page for each series.

▶ Reel & Packaging

Packaging Quantity & Reel Specifications (Unit: mm) (TRWL)

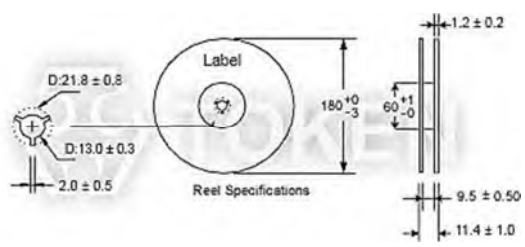
 <p>Packaging Quantity & Reel Specifications (TRWL)</p>	Type	Emboss Plastic Tape (PCS)
	TRWL08	2000
	TRWL06	2000
	TRWL05	2000
	TRWL03	4000
TRWL02	4000	

Emboss Plastic Tape Specifications (Unit: mm) (TRWL)

Codes	A ±0.10	B ±0.10	W ±0.2	E ±0.10	F ±0.1	P0 ±0.10	P1 ±0.10	P2 ±0.05	ΦD0 +0.10	t ±0.05
TRWL08	2.70	2.80	8.0	1.75	3.5	4.00	4.00	2.00	1.50	2.00
TRWL06	1.95	3.50	8.0	1.75	3.5	4.00	4.00	2.00	1.50	1.50
TRWL05	1.85	2.30	8.0	1.75	3.5	4.00	4.00	2.00	1.50	1.45
TRWL03	1.12	1.85	8.0	1.75	3.5	4.00	4.00	2.00	1.50	0.96
TRWL02	0.71	1.16	8.0	1.75	3.5	4.00	2.00	2.00	1.50	0.65

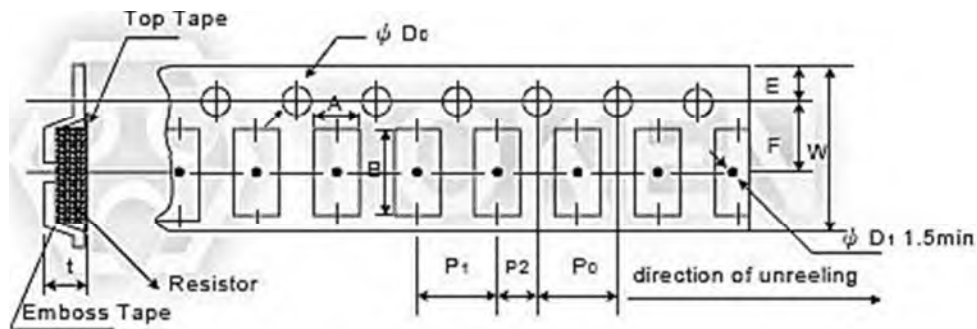

Emboss Plastic Tape Specifications (TRWL)

▶ Mechanical Test

Mechanical Performance Test (TRWL)

Item	Specification	Test Method
Vibration Test	Appearance: No damage L change: within $\pm 5\%$ Q change: within $\pm 10\%$	Test device shall be soldered on the substrate Oscillation Frequency: 10 to 55 to 10Hz for 1Min. Amplitude: 1.5mm Time: 2hrs for each axis (X, Y & Z), total 6hrs
Resistance to Soldering-Heat		Solder Temperature: $260\pm 5^{\circ}\text{C}$ Immersion Time: $10\pm 2\text{sec}$
Component Adhesion (Push Test)	1 lbs. For 0402 2 lbs. For 0603 3 lbs. For the rest	The device should be soldered ($260\pm 5^{\circ}\text{C}$ for 10 seconds) to a tinned copper subs rate. A dynamiter force gauge should be applied to the side of the component. The device must with stand a minimum force of 2 or 4 pounds without a failure of adhesion on termination
Drop Test	No damage	Dropping chip by each side and each corner. Drop 10 times in total Drop height: 100cm Drop weight: 125g
Solderability Test	90% covered with solder.	Inductor shall be dipped in a melted solder bath at $235\pm 5^{\circ}\text{C}$ for 5 seconds.
Resistance to Solvent Test	No damage on appearance and marking.	MIL-STD202F, Method 215D

▶ Electrical Test

Electrical Performance Test (TRWL)

Item	Specification	Test Method
Inductance	Refer to standard electrical characteristic spec.	HP4291B
Q		HP4291B
SRF		HP8753D
DC Resistance RDC		Micro-Ohm meter (Gom-801G)
Rated Current IDC		Applied the current to coils, The inductance change should be less than 10% to initial value
Over Load Test	Inductors shall have no evidence of electrical and mechanical damage	Applied 2 times of rated allowed DC current to inductor for a period of 5 minute
Withstanding Voltage Test	Inductors shall be no evidence of electrical and mechanical damage.	AC voltage of 500 VAC applied between inductors terminal and case for 1 minute.
Insulation Resistance Test	1000M ohm Min.	100 VDC applied between inductor terminal and case

► Climatic Test

Climatic Test (TRWL)

Item	Specification	Test Method															
Temperature Characteristic	Appearance: No damage L change: within $\pm 10\%$ Q change: within $\pm 20\%$	-40°C ~+125°C															
Humidity Resistance		Temperature: 40 \pm 2°C Relative Humidity: 90~95% Time: 96hrs \pm 2hrs Measured after exposure in the room condition for 2hrs															
Low Temperature Storage Test		Temperature: -40 \pm 2°C Time: 48 \pm 2hrs Inductors are tested after 1 hour at room temperature															
Thermal Shock Test		One cycle: <table border="1" style="margin-left: 20px;"> <thead> <tr> <th>Step</th> <th>Temperature (°C)</th> <th>time (Min.)</th> </tr> </thead> <tbody> <tr> <td>1</td> <td>-25\pm3</td> <td>30</td> </tr> <tr> <td>2</td> <td>25\pm2</td> <td>15</td> </tr> <tr> <td>3</td> <td>85\pm3</td> <td>30</td> </tr> <tr> <td>4</td> <td>25\pm2</td> <td>15</td> </tr> </tbody> </table> Total: 5 cycles	Step	Temperature (°C)	time (Min.)	1	-25 \pm 3	30	2	25 \pm 2	15	3	85 \pm 3	30	4	25 \pm 2	15
Step		Temperature (°C)	time (Min.)														
1		-25 \pm 3	30														
2		25 \pm 2	15														
3	85 \pm 3	30															
4	25 \pm 2	15															
High Temperature Storage Test	Temperature: 125 \pm 2°C Time: 48 \pm 2hrs Measured after exposure in the room condition for 1hr																
High Temperature Load Life Test	Temperature: 85 \pm 2°C Time: 1000 \pm 12hrs Load: Allowed DC current																
Humidity Load Life	Temperature: 40 \pm 2°C Relative Humidity: 90~95% Time: 1000 \pm 12hrs Load: Allowed DC current																

● Note: Storage Temperature: 25 \pm 3°C; Humidity: <80%RH



► Standard Electrical Specifications

Standard Electrical Specifications Standard (TRWL02) - EIA 0402

Part Number	Inductance (nH) @ 250MHz	Tolerance (%)	Q (Min.)	SRF (GHz)(Min.)	DCR (Ω)(Max.)	IDC (mA)	900MHz		1.7GHz	
							L	Q	L	Q
TRWL02*T1N0	1.0	10	16	12.70	0.04	1360	1.02	77	1.02	69
TRWL02*T1N9	1.9	10,5	16	11.30	0.07	1040	1.72	68	1.74	82
TRWL02*T2N0	2.0	10,5	16	11.10	0.07	1040	1.93	54	1.93	75
TRWL02*T2N2	2.2	10,5	19	10.80	0.07	960	2.19	59	2.23	100
TRWL02*T2N4	2.4	10,5	15	10.50	0.07	790	2.24	51	2.27	68
TRWL02*T2N7	2.7	10,5	16	10.40	0.12	640	2.23	42	2.25	61
TRWL02*T3N3	3.3	10,5,2	19	7.00	0.06	840	3.10	65	3.12	87
TRWL02*T3N6	3.6	10,5,2	19	6.80	0.06	840	3.56	45	3.62	71
TRWL02*T3N9	3.9	10,5,2	19	5.80	0.06	840	3.89	50	4.00	75
TRWL02*T4N3	4.3	10,5,2	18	6.00	0.09	700	4.19	47	4.30	71
TRWL02*T4N7	4.7	10,5,2	15	4.70	0.13	640	4.55	48	4.68	68
TRWL02*T5N1	5.1	10,5,2	20	4.80	0.08	800	5.15	56	5.25	82
TRWL02*T5N6	5.6	10,5,2	20	4.80	0.08	760	5.16	54	5.28	81
TRWL02*T6N2	6.2	10,5,2	20	4.80	0.08	760	6.16	52	6.37	76
TRWL02*T6N8	6.8	10,5,2	20	4.80	0.08	680	6.56	63	6.93	78
TRWL02*T7N5	7.5	10,5,2	22	4.80	0.10	680	7.91	60	8.22	88
TRWL02*T8N2	8.2	10,5,2	22	4.40	0.10	680	8.50	57	8.85	84
TRWL02*T8N7	8.7	10,5,2	18	4.10	0.20	480	8.78	54	9.21	73
TRWL02*T9N0	9.0	10,5,2	22	4.16	0.10	680	9.07	62	9.53	78
TRWL02*T9N5	9.5	10,5,2	18	4.00	0.20	480	9.42	54	9.98	69
TRWL02*T10N	10	10,5,2	21	3.90	0.19	480	9.80	50	10.10	67
TRWL02*T11N	11	10,5,2	24	3.68	0.12	640	10.70	52	11.20	78
TRWL02*T12N	12	10,5,2	24	3.60	0.12	640	11.90	53	12.70	71
TRWL02*T13N	13	10,5,2	24	3.45	0.21	440	13.40	51	14.60	57
TRWL02*T15N	15	10,5,2	24	3.28	0.17	560	14.60	55	15.50	77
TRWL02*T16N	16	10,5,2	24	3.10	0.22	560	16.60	46	18.80	47
TRWL02*T18N	18	10,5,2	24	3.10	0.23	420	18.30	57	20.28	62
TRWL02*T19N	19	10,5,2	24	3.04	0.20	480	19.10	50	21.10	67
TRWL02*T20N	20	10,5,2	25	3.00	0.25	420	20.70	52	23.66	53
TRWL02*T22N	22	10,5,2	25	2.80	0.30	400	23.20	53	26.75	53
TRWL02*T23N	23	10,5,2	22	2.72	0.30	400	23.80	49	26.90	64
TRWL02*T24N	24	10,5,2	25	2.70	0.30	400	25.10	51	29.50	50
TRWL02*T27N	27	10,5,2	24	2.48	0.30	400	28.70	49	33.50	63
TRWL02*T30N	30	10,5,2	25	2.35	0.35	400	31.10	46	38.50	39
TRWL02*T33N	33	10,5,2	24	2.35	0.35	400	34.90	31	41.74	32
TRWL02*T36N	36	10,5,2	24	2.32	0.44	320	39.50	44	48.40	53
TRWL02*T39N	39	10,5,2	25	2.10	0.55	200	41.70	47	50.23	45
TRWL02*T40N	40	10,5,2	24	2.24	0.44	320	39.00	44	47.40	33
TRWL02*T43N	43	10,5,2	25	2.03	0.81	100	45.80	46	61.55	34
TRWL02*T47N	47	10,5,2	20	2.10	0.83	150	50.00	38	-	-
TRWL02*T51N	51	10,5,2	25	1.75	0.82	100	-	-	-	-
TRWL02*T56N	56	10,5,2	22	1.76	0.97	100	-	-	-	-
TRWL02*T68N	68	10,5,2	22	1.62	1.12	100	-	-	-	-

● Note: Working Temperature Range: -40°C ~ 125°C



Standard Electrical Specifications Standard (TRWL03) - EIA 0603

Part Number	Inductance (nH)	Tolerance (%)	Q (Min.)	SRF (GHz)(Min.)	DCR (Ω)(Max.)	IDC (mA)	900MHz		1.7GHz		Color Code
							L	Q	L	Q	
Test Freq. @ 250MHz											
TRWL03*T1N6	1.6	10,5	24	12.5	0.030	700	1.53	35	1.58	55	Blue
TRWL03*T1N8	1.8	10,5	16	12.5	0.045	700	1.63	35	1.66	50	Black
TRWL03*T2N2	2.2	10,5	20	6.00	0.100	700	2.18	41	2.20	64	White
TRWL03*T2N7	2.7	10,5	16	>4.00	0.140	700	2.39	25	2.44	55	Yellow
TRWL03*T3N3	3.3	10,5,2	22	>6.00	0.080	700	3.35	47	3.40	65	Red
TRWL03*T3N6	3.6	10,5,2	22	5.80	0.063	700	3.53	49	3.58	65	Violet
TRWL03*T3N9	3.9	10,5,2	22	>6.00	0.080	700	3.95	49	3.96	67	Brown
TRWL03*T4N3	4.3	10,5,2	22	5.80	0.063	700	4.32	49	4.43	67	Orange
TRWL03*T4N5	4.5	10,5,2	20	5.80	0.120	700	4.74	55	4.87	92	Gray
TRWL03*T4N7	4.7	10,5,2	20	5.80	0.120	700	4.65	53	4.80	67	Violet
TRWL03*T5N1	5.1	10,5,2	20	5.80	0.160	700	5.13	47	5.36	56	Green
TRWL03*T5N6	5.6	10,5,2	20	5.80	0.170	700	5.53	56	5.86	77	Yellow
TRWL03*T6N2	6.2	10,5,2	25	5.80	0.110	700	6.28	60	6.40	85	Black
TRWL03*T6N3	6.3	10,5,2	25	5.80	0.110	700	6.67	41	6.86	61	Black
TRWL03*T6N8	6.8	10,5,2	27	5.80	0.110	700	6.75	60	7.10	81	Red
TRWL03*T7N5	7.5	10,5,2	28	4.80	0.106	700	7.70	60	7.82	65	Brown
TRWL03*T8N2	8.2	10,5,2	27	4.80	0.110	700	8.25	64	8.40	81	Green
TRWL03*T8N7	8.7	10,5,2	28	4.60	0.109	700	8.86	62	9.32	58	Yellow
TRWL03*T9N1	9.1	10,5,2	35	4.80	0.130	700	9.20	70	9.70	80	Black
TRWL03*T9N5	9.5	10,5,2	28	5.40	0.135	700	9.70	59	9.92	61	Blue
TRWL03*T10N	10.0	10,5,2	31	4.80	0.130	700	10.0	66	10.6	83	Orange
TRWL03*T11N	11.0	10,5,2	31	4.00	0.086	700	11.3	53	12.1	56	Gray
TRWL03*T12N	12.0	10,5,2	35	4.00	0.130	700	12.3	72	13.5	83	Yellow
TRWL03*T15N	15.0	10,5,2	35	4.00	0.170	700	15.4	64	16.8	89	Green
TRWL03*T16N	16.0	10,5,2	35	3.30	0.110	700	16.5	55	18.0	52	White
TRWL03*T17N	17.0	10,5,2	35	3.20	0.170	700	17.6	56	19.4	44	Red
TRWL03*T18N	18.0	10,5,2	35	3.10	0.170	700	18.7	70	21.4	69	Blue
TRWL03*T20N	20.0	10,5,2	40	3.00	0.190	700	20.7	80	23.5	30	Green
TRWL03*T22N	22.0	10,5,2	38	3.00	0.190	700	22.8	73	26.1	71	Violet
TRWL03*T23N	23.0	10,5,2	38	2.85	0.190	700	24.1	71	28.0	71	Orange
TRWL03*T24N	24.0	10,5,2	36	2.80	0.130	700	25.7	45	30.9	40	Black
TRWL03*T27N	27.0	10,5,2	40	2.80	0.220	600	29.2	74	34.6	65	Gray
TRWL03*T30N	30.0	10,5,2	37	2.80	0.150	600	31.4	47	39.8	28	Brown
TRWL03*T33N	33.0	10,5,2	40	2.30	0.220	600	36.0	67	49.5	42	White
TRWL03*T36N	36.0	10,5,2	37	2.30	0.250	600	39.1	47	48.9	24	Red
TRWL03*T39N	39.0	10,5,2	40	2.20	0.250	600	42.7	60	60.2	40	Black
Test Freq. @ 200MHz											
TRWL03*T43N	43.0	10,5,2	38	2.00	0.280	600	46.9	44	60.3	21	Orange
TRWL03*T47N	47.0	10,5,2	38	2.00	0.280	600	52.2	62	77.2	35	Brown
TRWL03*T51N	51.0	10,5,2	35	1.90	0.280	600	55.5	69	82.2	34	Blue
TRWL03*T56N	56.0	10,5,2	38	1.90	0.310	600	62.5	56	97.0	26	Red
TRWL03*T62N	62.0	10,5,2	37	1.80	0.340	600	68.0	40	110	10	Gray



Part Number	Inductance (nH)	Tolerance (%)	Q (Min.)	SRF (GHz)(Min.)	DCR (Ω)(Max.)	IDC (mA)	900MHz		1.7GHz		Color Code
							L	Q	L	Q	
TRWL03*T68N	68.0	10,5,2	37	1.70	0.340	600	80.5	54	168	21	Orange
Test Freq. @ 150MHz											
TRWL03*T72N	72.0	10,5,2	34	1.70	0.490	400	82.0	53	135	20	Yellow
TRWL03*T82N	82.0	10,5,2	34	1.70	0.540	400	96.2	54	177	21	Green
TRWL03*T91N	91.0	10,5,2	30	1.70	0.500	400	110	50	-	-	Brown
TRWL03*TR10	100	10,5,2	34	1.40	0.580	400	124	49	-	-	Blue
TRWL03*TR11	110	10,5,2	32	1.35	0.610	300	138	43	-	-	Violet
TRWL03*TR12	120	10,5,2	32	1.30	0.650	300	166	39	-	-	Gray
TRWL03*TR13	130	10,5,2	30	1.40	0.720	300	185	60	-	-	White
Test Freq. @ 100MHz											
TRWL03*TR14	140	10,5,2	28	1.30	0.870	280	190	80	-	-	Blue
TRWL03*TR15	150	10,5,2	32	1.30	0.950	280	230	25	-	-	White
TRWL03*TR16	160	10,5,2	25	1.30	1.400	280	215	-	-	-	Yellow
TRWL03*TR18	180	10,5,2	25	1.25	1.400	250	305	22	-	-	Black
TRWL03*TR22	220	10,5,2	25	1.20	1.600	250	377	-	-	-	Brown
TRWL03*TR26	260	10,5,2	25	1.00	2.000	200	469	-	-	-	Violet
TRWL03*TR27	270	10,5,2	25	0.90	2.100	200	-	-	-	-	Red
TRWL03*TR28	280	10,5,2	25	1.00	2.400	100	-	-	-	-	Green
TRWL03*TR30	300	10,5,2	25	0.75	2.500	150	-	-	-	-	Orange
TRWL03*TR33	330	10,5,2	25	0.90	3.800	100	-	-	-	-	Blue
TRWL03*TR39	390	10,5,2	25	0.90	4.350	100	-	-	-	-	Yellow

● Note: Working Temperature Range: -40°C ~ 125°C



Standard Electrical Specifications Standard (TRWL05) - EIA 0805

Part Number	Inductance (nH)	Tolerance (%)	Q (Min.)	SRF (GHz)(Min.)	DCR (Ω)(Max.)	IDC (mA)	Color Code
TRWL05*T2N7	2.7 @ 250MHz	10,5	80 @ 1500MHz	7.900	0.06	800	Brown
TRWL05*T2N8	2.8 @ 250MHz	10,5	80 @ 1500MHz	7.900	0.06	800	Gray
TRWL05*T3N0	3.0 @ 250MHz	10,5	65 @ 1500MHz	7.900	0.06	800	White
TRWL05*T3N3	3.3 @ 250MHz	10,5	50 @ 1500MHz	6.000	0.08	600	Black
TRWL05*T5N6	5.6 @ 250MHz	10,5	65 @ 1000MHz	5.500	0.08	600	Orange
TRWL05*T6N2	6.2 @ 250MHz	10,5	50 @ 1000MHz	5.500	0.11	600	Green
TRWL05*T6N8	6.8 @ 250MHz	10,5	50 @ 1000MHz	5.500	0.11	600	Brown
TRWL05*T7N5	7.5 @ 250MHz	10,5	50 @ 1000MHz	4.500	0.14	600	Green
TRWL05*T8N2	8.2 @ 250MHz	10,5	50 @ 1000MHz	4.700	0.12	600	Red
TRWL05*T8N7	8.7 @ 250MHz	10,5	50 @ 1000MHz	3.900	0.21	400	White
TRWL05*T10N	10.0 @ 250MHz	10,5,2	60 @ 500MHz	4.200	0.10	600	Blue
TRWL05*T12N	12.0 @ 250MHz	10,5,2	50 @ 500MHz	4.000	0.15	600	Orange
TRWL05*T15N	15.0 @ 250MHz	10,5,2	50 @ 500MHz	3.400	0.17	600	Yellow
TRWL05*T18N	18.0 @ 250MHz	10,5,2	50 @ 500MHz	3.300	0.20	600	Green
TRWL05*T22N	22.0 @ 250MHz	10,5,2	55 @ 500MHz	2.600	0.22	500	Blue
TRWL05*T24N	24.0 @ 250MHz	10,5,2	50 @ 500MHz	2.000	0.22	500	Gray
TRWL05*T27N	27.0 @ 250MHz	10,5,2	55 @ 500MHz	2.500	0.25	500	Violet
TRWL05*T33N	33.0 @ 250MHz	10,5,2	60 @ 500MHz	2.050	0.27	500	Gray
TRWL05*T36N	36.0 @ 250MHz	10,5,2	55 @ 500MHz	1.700	0.27	500	Orange
TRWL05*T39N	39.0 @ 250MHz	10,5,2	60 @ 500MHz	2.000	0.29	500	White
TRWL05*T43N	43.0 @ 200MHz	10,5,2	60 @ 500MHz	1.650	0.34	500	Yellow
TRWL05*T47N	47.0 @ 200MHz	10,5,2	60 @ 500MHz	1.650	0.31	500	Black
TRWL05*T56N	56.0 @ 200MHz	10,5,2	60 @ 500MHz	1.550	0.34	500	Brown
TRWL05*T68N	68.0 @ 200MHz	10,5,2	60 @ 500MHz	1.450	0.38	500	Red
TRWL05*T72N	72.0 @ 150MHz	10,5,2	65 @ 500MHz	1.400	0.40	500	Green
TRWL05*T82N	82.0 @ 150MHz	10,5,2	65 @ 500MHz	1.300	0.42	400	Orange
TRWL05*T91N	91.0 @ 150MHz	10,5,2	65 @ 500MHz	1.200	0.48	400	Black
TRWL05*TR10	100 @ 150MHz	10,5,2	65 @ 500MHz	1.200	0.46	400	Yellow
TRWL05*TR11	110 @ 150MHz	10,5,2	50 @ 250MHz	1.000	0.48	400	Brown
TRWL05*TR12	120 @ 150MHz	10,5,2	50 @ 250MHz	1.100	0.51	400	Green
TRWL05*TR15	150 @ 100MHz	10,5,2	50 @ 250MHz	0.920	0.56	400	Blue
TRWL05*TR18	180 @ 100MHz	10,5,2	50 @ 250MHz	0.870	0.64	400	Violet
TRWL05*TR20	200 @ 100MHz	10,5,2	50 @ 250MHz	0.860	0.66	400	Orange
TRWL05*TR22	220 @ 100MHz	10,5,2	50 @ 250MHz	0.850	0.70	400	Gray
TRWL05*TR24	240 @ 100MHz	10,5,2	44 @ 250MHz	0.690	1.00	350	Red
TRWL05*TR25	250 @ 100MHz	10,5,2	45 @ 250MHz	0.680	1.00	350	Green
TRWL05*TR27	270 @ 100MHz	10,5,2	48 @ 250MHz	0.650	1.00	350	White
TRWL05*TR30	300 @ 100MHz	10,5,2	48 @ 250MHz	0.620	1.20	330	Yellow
TRWL05*TR33	330 @ 100MHz	10,5,2	48 @ 250MHz	0.600	1.40	310	Black
TRWL05*TR36	360 @ 100MHz	10,5,2	48 @ 250MHz	0.580	1.45	300	Green
TRWL05*TR39	390 @ 100MHz	10,5,2	48 @ 250MHz	0.560	1.50	290	Brown
TRWL05*TR43	430 @ 50MHz	10,5,2	33 @ 100MHz	0.430	1.70	230	Blue
TRWL05*TR47	470 @ 50MHz	10,5,2	33 @ 100MHz	0.375	1.70	220	Red

Part Number	Inductance (nH)	Tolerance (%)	Q (Min.)	SRF (GHz)(Min.)	DCR (Ω)(Max.)	IDC (mA)	Color Code
TRWL05*TR56	560 @ 25MHz	10,5,2	23 @ 50MHz	0.340	1.90	210	Orange
TRWL05*TR60	600 @ 25MHz	10,5,2	23 @ 50MHz	0.260	1.60	450	White
TRWL05*TR62	620 @ 25MHz	10,5,2	23 @ 50MHz	0.220	2.20	210	Yellow
TRWL05*TR68	680 @ 25MHz	10,5,2	23 @ 50MHz	0.200	2.20	190	Green
TRWL05*TR75	750 @ 25MHz	10,5,2	23 @ 50MHz	0.200	2.30	180	Blue
TRWL05*TR82	820 @ 25MHz	10,5,2	23 @ 50MHz	0.200	2.35	180	Violet
TRWL05*T1R0	1000 @ 25MHz	10,5,2	20 @ 50MHz	0.100	2.50	170	Gray
TRWL05*T1R2	1200 @ 7.9MHz	10,5,2	18 @ 25MHz	0.100	2.50	170	White
TRWL05*T1R5	1500 @ 7.9MHz	10,5,2	16 @ 25MHz	0.100	2.50	170	Black
TRWL05*T1R8	1800 @ 7.9MHz	10,5,2	16 @ 7.9MHz	0.080	2.50	170	Brown
TRWL05*T2R2	2200 @ 7.9MHz	10,5,2	16 @ 7.9MHz	0.060	2.70	160	Red
TRWL05*T2R7	2700 @ 7.9MHz	10,5,2	16 @ 7.9MHz	0.050	2.95	150	Orange

● Note: Working Temperature Range: -40°C ~ 125°C



Standard Electrical Specifications Standard (TRWL06) - EIA 1206

Part Number	Inductance (nH)	Tolerance (%)	Q (Min.)	SRF (GHz)(Min.)	DCR (Ω)(Max.)	IDC (mA)	Color Code
TRWL06*T6N8	6.8 @ 100MHz	10,5	30 @ 300MHz	5.50	0.07	1000	Brown
TRWL06*T10N	10.0 @ 100MHz	10,5	40 @ 300MHz	4.00	0.08	1000	Red
TRWL06*T12N	12.0 @ 100MHz	10,5	40 @ 300MHz	3.20	0.08	1000	Orange
TRWL06*T15N	15.0 @ 100MHz	10,5	40 @ 300MHz	3.20	0.10	1000	Yellow
TRWL06*T18N	18.0 @ 100MHz	10,5	50 @ 300MHz	2.80	0.10	1000	Green
TRWL06*T22N	22.0 @ 100MHz	10,5	50 @ 300MHz	2.20	0.10	1000	Blue
TRWL06*T24N	24.0 @ 100MHz	10,5	50 @ 300MHz	2.00	0.10	1000	Red
TRWL06*T27N	27.0 @ 100MHz	10,5,2	50 @ 300MHz	1.80	0.11	1000	Violet
TRWL06*T33N	33.0 @ 100MHz	10,5,2	55 @ 300MHz	1.80	0.11	1000	Gray
TRWL06*T39N	39.0 @ 100MHz	10,5,2	55 @ 300MHz	1.80	0.12	1000	White
TRWL06*T47N	47.0 @ 100MHz	10,5,2	55 @ 300MHz	1.50	0.13	1000	Black
TRWL06*T56N	56.0 @ 100MHz	10,5,2	55 @ 300MHz	1.45	0.14	1000	Brown
TRWL06*T62N	62.0 @ 100MHz	10,5,2	55 @ 300MHz	1.20	0.20	1000	Violet
TRWL06*T68N	68.0 @ 100MHz	10,5,2	55 @ 300MHz	1.20	0.26	950	Red
TRWL06*T82N	82.0 @ 100MHz	10,5,2	55 @ 300MHz	1.20	0.21	920	Orange
TRWL06*T91N	91.0 @ 100MHz	10,5,2	55 @ 300MHz	1.10	0.24	900	White
TRWL06*TR10	100 @ 100MHz	10,5,2	55 @ 300MHz	1.10	0.26	850	Yellow
TRWL06*TR12	120 @ 100MHz	10,5,2	55 @ 300MHz	0.75	0.26	800	Green
TRWL06*TR15	150 @ 100MHz	10,5,2	60 @ 300MHz	0.95	0.31	750	Blue
TRWL06*TR18	180 @ 50MHz	10,5,2	55 @ 300MHz	0.90	0.43	700	Violet
TRWL06*TR22	220 @ 50MHz	10,5,2	55 @ 300MHz	0.76	0.50	670	Gray
TRWL06*TR27	270 @ 50MHz	10,5,2	55 @ 300MHz	0.74	0.56	630	White
TRWL06*TR30	300 @ 50MHz	10,5,2	50 @ 150MHz	0.68	0.60	600	Green
TRWL06*TR33	330 @ 50MHz	10,5,2	45 @ 150MHz	0.65	0.62	590	Black
TRWL06*TR36	360 @ 50MHz	10,5,2	45 @ 150MHz	0.60	0.65	550	Blue
TRWL06*TR39	390 @ 50MHz	10,5,2	45 @ 150MHz	0.60	0.75	530	Brown
TRWL06*TR47	470 @ 50MHz	10,5,2	45 @ 150MHz	0.55	1.30	490	Red
TRWL06*TR56	560 @ 35MHz	10,5,2	45 @ 150MHz	0.47	1.34	460	Orange
TRWL06*TR62	620 @ 35MHz	10,5,2	45 @ 150MHz	0.47	1.58	460	Gray
TRWL06*TR68	680 @ 35MHz	10,5,2	45 @ 150MHz	0.45	1.58	430	Yellow
TRWL06*TR75	750 @ 35MHz	10,5,2	45 @ 150MHz	0.44	2.25	320	White
TRWL06*TR82	820 @ 35MHz	10,5,2	45 @ 150MHz	0.42	1.82	400	Green
TRWL06*TR91	910 @ 35MHz	10,5,2	45 @ 150MHz	0.41	2.95	310	Green
TRWL06*T1R0	1000 @ 35MHz	10,5,2	45 @ 150MHz	0.40	2.80	320	Blue
TRWL06*T1R2	1200 @ 35MHz	10,5,2	45 @ 150MHz	0.38	3.20	300	Violet

● Note: Working Temperature Range: -40°C ~ 125°C



Standard Electrical Specifications Standard (TRWL08) - EIA 1008

Part Number	Inductance (nH)	Tolerance (%)	Q (Min.)	SRF (GHz)(Min.)	DCR (Ω)(Max.)	IDC (mA)	Color Code
TRWL08*T5N6	5.6 @ 50MHz	10,5	50 @ 1500MHz	4.000	0.15	1000	Black
TRWL08*T10N	10 @ 50MHz	10,5,2	50 @ 500MHz	4.100	0.08	1000	Brown
TRWL08*T12N	12 @ 50MHz	10,5,2	50 @ 500MHz	3.300	0.09	1000	Red
TRWL08*T15N	15 @ 50MHz	10,5,2	50 @ 500MHz	2.500	0.11	1000	Orange
TRWL08*T18N	18 @ 50MHz	10,5,2	50 @ 350MHz	2.400	0.12	1000	Yellow
TRWL08*T22N	22 @ 50MHz	10,5,2	55 @ 350MHz	2.400	0.12	1000	Green
TRWL08*T24N	24 @ 50MHz	10,5,2	55 @ 350MHz	1.900	0.12	1000	Blue
TRWL08*T27N	27 @ 50MHz	10,5,2	55 @ 350MHz	1.600	0.13	1000	Violet
TRWL08*T33N	33 @ 50MHz	10,5,2	60 @ 350MHz	1.600	0.14	1000	Gray
TRWL08*T36N	36 @ 50MHz	10,5,2	60 @ 350MHz	1.600	0.15	1000	Orange
TRWL08*T39N	39 @ 50MHz	10,5,2	60 @ 350MHz	1.500	0.15	1000	White
TRWL08*T47N	47 @ 50MHz	10,5,2	65 @ 350MHz	1.500	0.16	1000	Black
TRWL08*T56N	56 @ 50MHz	10,5,2	65 @ 350MHz	1.300	0.18	1000	Brown
TRWL08*T62N	59 @ 50MHz	10,5,2	65 @ 350MHz	1.250	0.20	1000	Blue
TRWL08*T68N	68 @ 50MHz	10,5,2	65 @ 350MHz	1.300	0.20	1000	Red
TRWL08*T75N	75 @ 50MHz	10,5,2	60 @ 350MHz	1.100	0.21	1000	White
TRWL08*T82N	82 @ 50MHz	10,5,2	60 @ 350MHz	1.000	0.22	1000	Orange
TRWL08*TR10	100 @ 25MHz	10,5,2	60 @ 350MHz	1.000	0.56	650	Yellow
TRWL08*TR12	120 @ 25MHz	10,5,2	60 @ 350MHz	0.950	0.63	650	Green
TRWL08*TR15	150 @ 25MHz	10,5,2	45 @ 100MHz	0.850	0.70	580	Blue
TRWL08*TR18	180 @ 25MHz	10,5,2	45 @ 100MHz	0.750	0.77	620	Violet
TRWL08*TR22	220 @ 25MHz	10,5,2	45 @ 100MHz	0.700	0.84	500	Gray
TRWL08*TR24	240 @ 25MHz	10,5,2	45 @ 100MHz	0.650	0.88	500	White
TRWL08*TR27	270 @ 25MHz	10,5,2	45 @ 100MHz	0.600	0.91	500	Black
TRWL08*TR30	300 @ 25MHz	10,5,2	45 @ 100MHz	0.585	1.00	450	Brown
TRWL08*TR33	330 @ 25MHz	10,5,2	45 @ 100MHz	0.570	1.05	450	Red
TRWL08*TR36	360 @ 25MHz	10,5,2	45 @ 100MHz	0.530	1.10	470	Orange
TRWL08*TR39	390 @ 25MHz	10,5,2	45 @ 100MHz	0.500	1.12	470	Yellow
TRWL08*TR43	430 @ 25MHz	10,5,2	45 @ 100MHz	0.480	1.15	470	Green
TRWL08*TR47	470 @ 25MHz	10,5,2	45 @ 100MHz	0.450	1.19	470	Blue
TRWL08*TR56	560 @ 25MHz	10,5,2	45 @ 100MHz	0.415	1.33	400	Violet
TRWL08*TR62	620 @ 25MHz	10,5,2	45 @ 100MHz	0.375	1.40	300	Gray
TRWL08*TR68	680 @ 25MHz	10,5,2	45 @ 100MHz	0.375	1.47	400	White
TRWL08*TR75	750 @ 25MHz	10,5,2	45 @ 100MHz	0.360	1.54	360	Black
TRWL08*TR82	820 @ 25MHz	10,5,2	45 @ 100MHz	0.350	1.61	400	Brown
TRWL08*TR91	910 @ 25MHz	10,5,2	35 @ 50MHz	0.320	1.68	380	Red
TRWL08*T1R0	1000 @ 25MHz	10,5,2	35 @ 50MHz	0.290	1.75	370	Orange
TRWL08*T1R2	1200 @ 7.9MHz	10,5,2	35 @ 50MHz	0.250	2.00	310	Yellow
TRWL08*T1R5	1500 @ 7.9MHz	10,5,2	28 @ 50MHz	0.200	2.30	330	Green
TRWL08*T1R8	1800 @ 7.9MHz	10,5,2	28 @ 50MHz	0.160	2.60	300	Blue
TRWL08*T2R2	2200 @ 7.9MHz	10,5,2	28 @ 50MHz	0.160	2.80	280	Violet
TRWL08*T2R7	2700 @ 7.9MHz	10,5,2	22 @ 25MHz	0.140	3.20	290	Gray
TRWL08*T3R3	3300 @ 7.9MHz	10,5,2	22 @ 25MHz	0.110	3.40	290	White
TRWL08*T3R9	3900 @ 7.9MHz	10,5,2	20 @ 25MHz	0.100	3.60	260	Black
TRWL08*T4R7	4700 @ 7.9MHz	10,5,2	18 @ 25MHz	0.090	4.00	260	Brown
TRWL08*T5R6	5600 @ 7.9MHz	10,5,2	16 @ 7.96MHz	0.020	4.00	240	Red
TRWL08*T6R8	6800 @ 7.9MHz	10,5,2	15 @ 7.96MHz	0.040	4.90	200	Orange
TRWL08*T8R2	8200 @ 7.9MHz	10,5,2	15 @ 7.96MHz	0.025	6.00	170	Yellow
TRWL08*T100	10000 @ 2.52MHz	10,5,2	15 @ 7.96MHz	0.020	9.00	150	Green
TRWL08*T120	12000 @ 2.52MHz	10,5,2	15 @ 7.96MHz	0.018	10.5	130	Blue
TRWL08*T150	15000 @ 2.52MHz	10,5,2	15 @ 7.96MHz	0.015	11.5	120	Violet

● Note: Working Temperature Range: -40°C ~ 125°C

Test Methods/Instrument: Network Spectrum Analyzer.



Standard Electrical Specifications Low Profile (TRWL05) - EIA 0805

Part Number	Inductance (nH)	Tolerance (%)	Q (Min.)	SRF (GHz)(Min.)	DCR (Ω)(Max.)	IDC (mA)	Color Code
TRWL05*TL1N8	1.8 @ 250MHz	10	55 @ 1500MHz	9.40	0.03	800	Black
TRWL05*TL3N9	3.9 @ 250MHz	10,5	50 @ 1000MHz	6.10	0.06	800	Brown
TRWL05*TL4N7	4.7 @ 250MHz	10,5	50 @ 1000MHz	5.50	0.06	800	Red
TRWL05*TL6N8	6.8 @ 250MHz	10,5	50 @ 1000MHz	5.50	0.08	800	Orange
TRWL05*TL8N2	8.2 @ 250MHz	10,5	50 @ 1000MHz	4.80	0.08	800	Yellow
TRWL05*TL10N	10.0 @ 250MHz	10,5,2	55 @ 750MHz	3.30	0.08	800	Green
TRWL05*TL12N	12.0 @ 250MHz	10,5,2	55 @ 750MHz	3.80	0.10	800	Blue
TRWL05*TL15N	15.0 @ 250MHz	10,5,2	50 @ 500MHz	2.95	0.10	800	Violet
TRWL05*TL18N	18.0 @ 250MHz	10,5,2	50 @ 500MHz	3.10	0.13	800	Gray
TRWL05*TL22N	22.0 @ 250MHz	10,5,2	50 @ 500MHz	2.90	0.15	800	Whit
TRWL05*TL27N	27.0 @ 250MHz	10,5,2	50 @ 500MHz	2.45	0.23	600	Black
TRWL05*TL33N	33.0 @ 250MHz	10,5,2	50 @ 500MHz	2.35	0.28	600	Brown
TRWL05*TL39N	39.0 @ 250MHz	10,5,2	50 @ 500MHz	2.20	0.33	600	Red
TRWL05*TL47N	47.0 @ 200MHz	10,5,2	50 @ 500MHz	2.00	0.39	600	Orange
TRWL05*TL56N	56.0 @ 200MHz	10,5,2	50 @ 500MHz	1.85	0.39	500	Yellow
TRWL05*TL68N	68.0 @ 200MHz	10,5,2	50 @ 500MHz	1.50	0.40	500	Green
TRWL05*TL82N	82.0 @ 150MHz	10,5,2	50 @ 500MHz	1.50	0.44	500	Blue
TRWL05*TLR10	100.0 @ 150MHz	10,5,2	50 @ 500MHz	1.20	0.64	400	Violet
TRWL05*TLR12	120.0 @ 150MHz	10,5,2	40 @ 250MHz	1.15	0.68	300	Gray
TRWL05*TLR15	150.0 @ 150MHz	10,5,2	40 @ 250MHz	1.05	0.80	300	Whit
TRWL05*TL1R0	1000.0 @ 25MHz	10,5,2	16 @ 50MHz	0.08	2.00	220	Black

● Note: Working Temperature Range: -40°C ~ 125°C



Standard Electrical Specifications Low Profile (TRWL08) - EIA 1008

Part Number	Inductance (nH)	Tolerance (%)	Q (Min.)	SRF (GHz)(Min.)	DCR (Ω)(Max.)	IDC (mA)	Color Code
TRWL08*TL4N2	4.2 @ 50MHz	10,5	42 @ 1500MHz	6.00	0.15	600	Black
TRWL08*TL6N8	6.8 @ 50MHz	10,5	50 @ 1500MHz	5.40	0.17	600	Brown
TRWL08*TL8N2	8.2 @ 50MHz	10,5	50 @ 1500MHz	5.00	0.22	600	Red
TRWL08*TL15N	15 @ 50MHz	10,5	57 @ 500MHz	3.00	0.22	600	Orange
TRWL08*TL20N	20 @ 50MHz	10,5	72 @ 500MHz	2.40	0.33	600	Yellow
TRWL08*TL27N	27 @ 50MHz	10,5	50 @ 350MHz	1.60	0.13	600	Green
TRWL08*TL30N	30 @ 50MHz	10,5	69 @ 500MHz	2.40	0.38	600	Blue
TRWL08*TL40N	40 @ 50MHz	10,5	67 @ 500MHz	2.00	0.43	600	Violet
TRWL08*TL50N	50 @ 50MHz	10,5,2	72 @ 500MHz	1.90	0.48	600	Gray
TRWL08*TL60N	60 @ 50MHz	10,5,2	75 @ 500MHz	1.80	0.52	600	White
TRWL08*TL70N	70 @ 50MHz	10,5,2	68 @ 500MHz	1.70	0.55	510	Black
TRWL08*TL80N	80 @ 50MHz	10,5,2	75 @ 500MHz	1.40	0.56	510	Brown
TRWL08*TLR56	560 @ 25MHz	10,5,2	40 @ 100MHz	0.40	1.33	400	Red

● Note: Working Temperature Range: -40°C ~ 125°C

Standard Electrical Specifications High Current (TRWL03) - EIA 0603

Part Number	Inductance (nH)	Tolerance (%)	Q (Min.)	SRF (GHz)(Min.)	DCR (Ω)(Max.)	IDC (mA)	Color Code
TRWL03*TH1N6	1.6 @ 250MHz	10,5	24	12.50	0.030	2400	Black
TRWL03*TH3N6	3.6 @ 250MHz	10,5	24	5.90	0.048	2300	Brown
TRWL03*TH3N9	3.9 @ 250MHz	10,5	25	5.90	0.054	2200	Red
TRWL03*TH6N8	6.8 @ 250MHz	10,5	35	5.80	0.054	2100	Orange
TRWL03*TH7N5	7.5 @ 250MHz	10,5	35	3.70	0.059	2100	Yellow
TRWL03*TH8N2	8.2 @ 250MHz	10,5	38	3.70	0.060	2000	White
TRWL03*TH10N	10.0 @ 250MHz	10,5,2	38	3.70	0.071	2000	Green
TRWL03*TH12N	12.0 @ 250MHz	10,5,2	38	3.00	0.075	2000	Blue
TRWL03*TH15N	15.0 @ 250MHz	10,5,2	38	2.80	0.080	1900	Violet
TRWL03*TH18N	18.0 @ 250MHz	10,5,2	40	2.80	0.099	1900	Gray
TRWL03*TH22N	22.0 @ 250MHz	10,5,2	42	2.40	0.099	1800	White
TRWL03*TH24N	24.0 @ 250MHz	10,5,2	42	2.40	0.105	1800	Black

● Note: Working Temperature Range: -40°C ~ 125°C

Standard Electrical Specifications High Q (TRWL05) - EIA 0805

Part Number	Inductance (nH)	Tolerance (%)	Q (Min.)	SRF (GHz)(Min.)	DCR (Ω)(Max.)	IDC (mA)	Color Code
TRWL05*TH2N5	2.5 @ 250MHz	10,5	80 @ 1500MHz	6.00	0.020	1600	Black
TRWL05*TH5N6	5.6 @ 250MHz	10,5	98 @ 1500MHz	6.00	0.035	1600	Brown
TRWL05*TH6N2	6.2 @ 250MHz	10,5	88 @ 1000MHz	4.75	0.035	1600	Red
TRWL05*TH6N8	6.8 @ 250MHz	10,5	80 @ 1000MHz	4.40	0.035	1600	White
TRWL05*TH8N2	8.2 @ 250MHz	10,5	75 @ 1000MHz	3.00	0.075	1000	Gray
TRWL05*TH12N	12 @ 250MHz	10,5	80 @ 1000MHz	3.00	0.045	1600	Orange
TRWL05*TH15N	15 @ 250MHz	10,5,2	80 @ 1000MHz	2.80	0.100	1200	Black
TRWL05*TH16N	16 @ 250MHz	10,5,2	72 @ 500MHz	2.95	0.060	1500	Yellow
TRWL05*TH18N	18 @ 250MHz	10,5,2	75 @ 500MHz	2.55	0.060	1400	Green
TRWL05*TH20N	20 @ 250MHz	10,5,2	70 @ 500MHz	2.05	0.055	1400	Blue
TRWL05*TH22N	22 @ 250MHz	10,5,2	80 @ 500MHz	2.00	0.100	1200	Black
TRWL05*TH27N	27 @ 250MHz	10,5,2	75 @ 500MHz	2.00	0.070	1300	Violet
TRWL05*TH30N	30 @ 250MHz	10,5,2	65 @ 500MHz	1.95	0.095	1200	Gray
TRWL05*TH39N	39 @ 250MHz	10,5,2	65 @ 500MHz	1.60	0.110	1100	White
TRWL05*TH48N	48 @ 200MHz	10,5,2	65 @ 500MHz	1.40	0.095	1200	Black
TRWL05*TH51N	51 @ 200MHz	10,5,2	65 @ 500MHz	1.40	0.120	1000	Brown

● Note: Working Temperature Range: -40°C ~ 125°C

Standard Electrical Specifications High Q (TRWL08) - EIA 1008

Part Number	Inductance (nH)	Tolerance (%)	Q (Min.)	SRF (GHz)(Min.)	DCR (Ω)(Max.)	IDC (mA)	Color Code
TRWL08*TH3N0	3.0 @ 50MHz	10,5	70 @ 1500MHz	6.00	0.04	1600	Black
TRWL08*TH4N1	4.1 @ 50MHz	10,5	75 @ 1500MHz	6.00	0.05	1600	Brown
TRWL08*TH7N8	7.8 @ 50MHz	10,5	75 @ 500MHz	3.80	0.05	1600	Red
TRWL08*TH10N	10 @ 50MHz	10,5,2	60 @ 500MHz	3.60	0.06	1600	Orange
TRWL08*TH12N	12 @ 50MHz	10,5,2	70 @ 500MHz	2.80	0.06	1500	Yellow
TRWL08*TH18N	18 @ 50MHz	10,5,2	62 @ 350MHz	2.70	0.07	1400	Green
TRWL08*TH22N	22 @ 50MHz	10,5,2	62 @ 350MHz	2.05	0.07	1400	Blue
TRWL08*TH33N	33 @ 50MHz	10,5,2	75 @ 350MHz	1.70	0.09	1300	Violet
TRWL08*TH39N	39 @ 50MHz	10,5,2	75 @ 350MHz	1.30	0.09	1300	Gray
TRWL08*TH47N	47 @ 50MHz	10,5,2	75 @ 350MHz	1.45	0.12	1200	White
TRWL08*TH56N	56 @ 50MHz	10,5,2	75 @ 350MHz	1.23	0.12	1200	Black
TRWL08*TH68N	68 @ 50MHz	10,5,2	80 @ 350MHz	1.15	0.13	1100	Brown
TRWL08*TH82N	82 @ 50MHz	10,5,2	80 @ 350MHz	1.06	0.16	1100	Red
TRWL08*THR10	100 @ 50MHz	10,5,2	52 @ 350MHz	0.82	0.16	1000	Orange

● Note: Working Temperature Range: -40°C ~ 125°C

Parts (3.0nH, 7.8nH) are wound on a low profile bobbin with High Q.

▶ Order Codes

Order Codes (TRWL)

TRWL	03			J		T		S		1N6		S	
Part Number	Dimensions (L×W) (mm)			Resistance Tolerance		Package		Design code		Inductance		TerMin.al	
TRWL	02	1.00×0.50	EIA0402	G	±2%	T	Taping Reel	S	Standard Inductor	1N6	1.6nH	G	Mo / Mn Or W with Gold plated.
	03	1.60×0.80	EIA0603	J	±5%			L	Low Profile Inductor	82N	82nH		
	05	2.00×1.20	EIA0805	K	±10%					R27	270nH		
	06	3.20×1.60	EIA1206	M	±20%					1R0	1000nH	S	Pd / Ag with Tin plated.
	08	2.50×2.00	EIA1008					H	High Current and High Q	100	10000nH		

► General Information

Token Cuts Inductor Size and Cost

Token utilizes the latest technology enabling the most cost-effective designs in manufacturing inductors. The 0402, 0603, 0805, 1206, 1210, to 1812 series of RF Miniature Inductors all contain wire wound or multi-layer technology with material substrate in ceramic or ferrite cores. Thus providing economic cost with the ultimate performance demanded by today's RF applications. Inductors feature high Q factor, SRFs (self-resonant or series resonant frequency), and I_{dc} (maximum current carrying capacity).

How to quickly search RF inductors for all of the characteristics?

Searching and comparing data sheets of inductor manufacturers can be time consuming. Token's Parameter Sorting Search Mode allows selection of inductors based on different parameters. To enter Searching Mode:

- By entering just the inductance value,
- By sorting parameter to narrow down searching range,
- Or by enter keyword / part number / size dimensions L*W*H to partial or exact searching.

Inductors Selection Notes:

For choke applications, the SRFs (self-resonant or series resonant frequency) is the frequency that provides the best signal blocking.

- At the SRF, impedance is at its maximum.
- At frequencies below the SRF, impedance increases with frequency.
- At frequencies above the SRF, impedance decreases with frequency.

For higher order filter or impedance matching applications, in general, the choice of inductance value typically determines the SRF and vice versa. The higher the inductance value, the lower the SRF, due to increased winding capacitance. It is more important to have a relatively flat inductance curve (constant inductance vs. frequency) near the required frequency. This suggests selecting an inductor with an SRF well above the design frequency. A rule of thumb is to select an inductor with an SRF that is a decade (10X) higher than the operating frequency.

What is Q factor? High Q leads to low insertion loss, minimizing power consumption, and narrow bandwidth. It is important if the inductor is to be used as part of an LC (oscillator) circuit or in narrow band pass applications. In general, wire wound inductors have much higher Q values than multilayer inductors of the same size and value. Token's material science and manufacturing expertise effectively bridges the gap between wire-wound performance and multi-layer inductors with its TRMF100505 (EIA 0402) and TRMI160808 (EIA 0603) series.

How does current requirement affect inductor? Higher current requires larger wire or more threads of the same wire size to keep losses and temperature rise to a minimum. Larger wire lowers the DCR and increases the Q factor. Using a ferrite core inductor with a lower turn count can achieve higher current capacity and lower DCR. Ferrite, however, may introduce new limitations such as larger variation of inductance with temperature, looser tolerances, lower Q, and reduced saturation current ratings. Token's ferrite inductors with open magnetic structures, will not saturate, even at full rated current.

