

Version:
December 1, 2022



(DRB20) Power Wirewound Vitreous Enameled Resistors

Token Electronics Industry Co., Ltd.

Taiwan: No.137, Sec. 1, Zhongxing Rd., Wugu District,
New Taipei City, Taiwan. 248012
Tel: +886 2981 0109 Fax: +886 2988 7487

China: 17P, Nanyuan Maple Leaf Bldg., Nanshan Ave.,
Nanshan Dist., Shenzhen, Guangdong, China. 518054
Tel: +86 755 26055363

[Web: www.token.com.tw](http://www.token.com.tw)

[Email: rfq@token.com.tw](mailto:rfq@token.com.tw)



▶ Product Introduction

Token (DRB20) Vitreous Enameled Resistors - strong moisture-proof characteristics, high energy power.

Features :

- Small size, high power.
- Glaze coating, simple structure, easy to install.
- Fixed resistance and adjustable resistance optional.

Applications :

- Electric tools, Consumer product applications.
- Power supply, high voltage applications.
- Welding machine, switch applications.

Power Wirewound Enameled Resistor (DRB20) Is a cylindrical ceramic tube at both ends clips to fixed terminals. Ceramic tube winding copper nickel or nickel-chromium alloy resistance wire. Surface coated with moisture-resistant, heat-resistant, non-corrosive, non-flammable coatings (such as silicone, epoxy, cement, glazed porcelain, etc.). After high temperature treatment, the resistor dried and insulation fixed, then fitted with fixed foot frame.



Due to good flexibility, (DRB20) can be made of multi-terminal, low inductive resistance, semi-adjustable type of various types of resistors. Resistance range from 1.7Ω to $75K\Omega$, with power ranges from 8W to 500W, and optional tolerance accuracy of $\pm 1\%$ 、 $\pm 5\%$ 、 $\pm 10\%$. Size of cylindrical ceramic tube matches with industry standards.

Tubular series power-glaze wire wound resistor (DRB20) widely used as brake resistors, bleeder resistors, aging resistors, brake resistors. According to different occasions, but also can be called brake resistors, discharge resistors, load resistors, current limiting resistors, charging resistors or discharge resistors. Non-inductance series adopts Ayrton Perry winding method to eliminate inductance parasitic effect, so as to minimize inductance, suitable for high energy consumption, high-temperature environment.

Be glazed coating protection, not afraid of external mechanical strength and dust environment. Not only large power and strong, shock-resistant, but also features good heat dissipation. This (DRB20) is easy to install and use. This is suitable for a variety of applications. More than 1.2 times the same specifications or requirements of peer production, more power, can be long time loading and impact. Applications include industrial machinery, load testing, power distribution, instrumentation and automation control devices.

Token Electronics (DRB20) vitreous enameled power wirewound resistors meet RoHS compliant, lead-free standard and short production cycle. Those Products widely used in power tools, switch applications, power supplies, welding machines, high voltage applications, consumer product applications, home entertainment, home appliances products. For the customized special applications, please contact our sales to discuss the details. Or link to Token official website "[General Purpose Resistors](http://www.token.com.tw)" for more information.



► Technical Specifications

Power Wirewound Glaze Resistors (DRB20) Dimensions (Unit: mm)

Type	Dimensions (mm)									
	L	D	d	H	h	L1	K	b	t	d1
DRB20(T*)-8	35±1.5	14±2	5.5±0.5		28.5±2.5			3.5±0.8	4.5±1	2±0.8
DRB20(T)-10	41±1.5	14±2	5.5±0.5	31±3	28.5±2.5	20±2	6±2	3.5±0.8	4.5±1	2±0.8
DRB20(T)-16	45±1.5	17±2	8±0.5	34±3	31±2.5	23±2	6±2	3.5±0.8	4.5±1	2±0.8
DRB20(T)-20	51±2	17±2	8±0.5	34±3	31±2.5	30±3	6±2	3.5±0.8	4.5±1	2±0.8
DRB20(T)-25	51±2	21±2.5	12±0.6	39±3	35±2.5	30±3	6±2	3.5±0.8	4.5±1	2±0.8
DRB20(T)-30	71±2.2	21±2.5	12±0.6	39±3	35±2.5	44±3	6±2	3.5±0.8	4.5±1	2±0.8
DRB20(T)-40	87±2.2	21±2.5	12±0.6	39±3	35±2.5	57±3		3.5±0.8	4.5±1	2±0.8
DRB20(T)-50	91±2.4	29±3	20±1.1	47±3	43±2.5	60±3	7±2	4.5±1	6±1	2.5±0.8
DRB20(T)-75	140±3.2	29±3	20±1.1	47±3	43±2.5	110±3	7±2	4.5±1	6±1	2.5±0.8
DRB20(T)-100	170±3.5	29±3	20±1.1	47±3	43±2.5	140±3	7±2	4.5±1	6±1	2.5±0.8
DRB20(T)-150	215±4	29±3	20±1.1	47±3	43±2.5	185±3	7±2	4.5±1	6±1	4±0.8
DRB20(T)-200	215±4	38±3	38±3	61±3	58±2	160±3	7±2	8±1	9±1	4±0.8
DRB20(T)-250	266±4	30±2	30±2	50±3	50±2	210±4	7±2	8±1	9±1	4±0.8
DRB20(T)-300	266±4	36±2	36±2	58±3	58±2	210±4	8±2	8±1	9±1	4±0.8
DRB20(T)-400	250±4	54±2	54±2	76±3	77±3	180±4	10±2	8±1	16±1	8±1
DRB20(T)-500	300±4	54±2	30±2	76±3	77±3	230±4	10±2	8±1	16±1	8±1

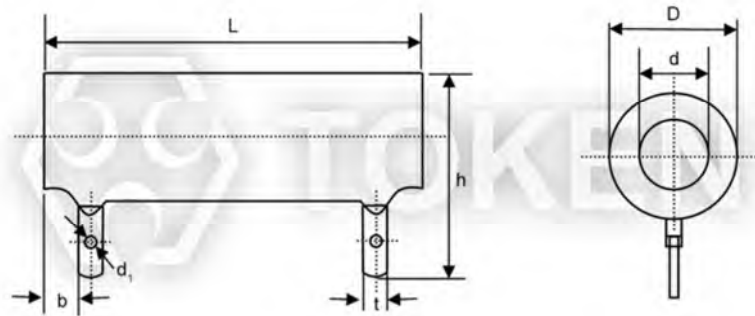

Power Wirewound Glaze Resistors (DRB20) Dimensions (Unit: mm)

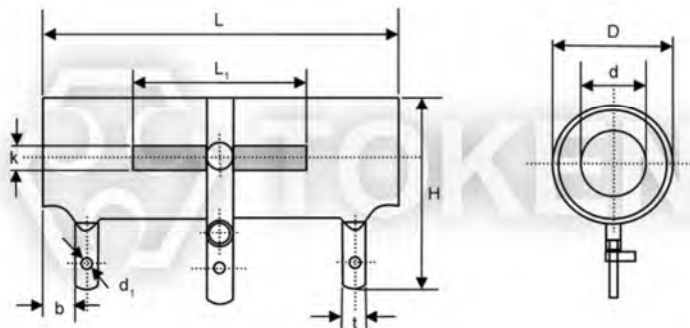

Power Wirewound Glaze Adjustable Resistors (DRB20-T) Dimensions (Unit: mm)

- T* : Adjustable Wirewound Resistors ●

► Specification

Power Wirewound Vitreous Enameled Resistors (DRB20) Specification

Type	Rating Power (W)	Resistance (Ω)		Weight (g)	
		DRB20	DRB20-T	Fixed	Adjustable
DRB20 (DRB20T)	8	5.1-3.3K		23	
	10	5.1-10K	5.1-200	17	34
	16	5.1-15K	5.1-220	36	42
	20	5.1-20K	5.1-430	44	52
	25	10-24	10-510	57	68
	30	10-30K	10-1K	80	90
	40	20-51K	20-1.2K	98	110
	50	24-56K	20-1.5K	132	150
	75	20-51K	24-2K	253	270
	100	24-62K	20-4.3K	286	200
	150	20-75K	20-4.3K	385	300
	200	4.7-68K	5.1-4.3K	475	400
	250	4.7-68K	5.1-4.3K	510	530
	300	1.7-68K	5.1-4.3K	630	650
	400	4.7-75K	6.2-5.1K	1000	1050
500	4.7-75K	6.2-5.1K	1340	1400	

► Electrical Performance

Power Wirewound Enameled Resistor (DRB20) Performance

Test Item	Characteristics	Test Methods
Solderability	Even sticky tin	HiSnPb39, 75W Soldering iron method, tinning
Insulation resistance	>20M Ω /cm ²	500V DC test voltage
Insulation voltage	No breakdown, arcing	2000V DC or 50Hz AC peak with the same
Body strength	$\Delta R \leq \pm (1\%R + 0.05\Omega)$	$\leq 40W$ Loading 30N, $\geq 50W$ Loading 100N
Vibration	$\Delta R \leq \pm (1\%R + 0.05\Omega)$	Frequency 10-500Hz, Acceleration 98m/s ² , 1h
Collision test	$\Delta R \leq \pm (1\%R + 0.05\Omega)$	Frequency 40-80 次/Min., Acceleration 245m/s ² , 2000 times
Temperature Rise	<325°C	Apply rated power Load
Rapid temperature changes	$\Delta R \leq \pm (2\%R + 0.1\Omega)$	$\theta A = -55^\circ C$ $\theta B = +200^\circ C$, 5 Cycles
Constant Damp Heat	$\Delta R \leq \pm (2\%R + 0.1\Omega)$	Temperature 40 \pm 2°C, Temperature 93 \pm 2%RH, 96h
Over loading	$\Delta R \leq \pm (2\%R + 0.1\Omega)$	Apply 10 times the rated power load 5s
Room temperature durability	$\Delta R \leq \pm (5\%R + 0.1\Omega)$	Apply rated power load 1000h

▶ Application Notes

Adjustable Wirewound Application Notes

Determination of End Resistance Value of (DRB20-T):

1. Resistance Range means you can choose one maximum resistance value (Max. Pickable Resistance / End resistance value) at one of DRB20-T, FVR, DQS, DSRA, DSRB, BSR, BSQ, VR (Variable Resistor) type.
2. After End Resistance Value confirmed, the minimum resistance (start resistance value) will be determined by depending on resistance of wire and wirewound type.

Power Rating of Variable Resistor:

The part Number formation of DRB20-T:

Product type - Rated Wattage - Max. Pickable Resistance (Ω) - Resistance Tolerance

Product type means one of FVR, DQS, DSRA, DSRB, BSR, BSQ, DRB20-T.

Rated Wattage means power rating at End Resistance Value.

Resistance Value (Ω) means maximum resistance value (End Resistance Value).

Resistance Tolerance means precision range of End Resistance Value.

1. Power Rating of VR (Variable Resistor) is determined by the maximum resistance value (End Resistance Value).
2. Resistance and Power Rating should be decreased while you are adjusting the screw.

Notes:

1. Adjustability is 10% to 90% of full resistance value.
2. Wattage is proportional to this adjusted resistance value.

Power Rating:

1. Based on 25°C free air rating. The stated wattage rating applies only when the entire resistance is in the circuit.
2. Setting the lug at an intermediate point reduces the wattage rating by approximately the same proportion.
3. Example: If the lug is set at half resistance, the wattage is reduced by approximately one-half.

If you need current constant type or special specifications, please feel free to contact us.

Order Codes

Power Wirewound Vitreous Glaze Resistors - (DRB20) Order Codes

DRB20	-	T	8W		100R		J		
Type		Adjustable Resistance	Rating Power (W)		Resistance Value (Ω)		Resistance Tolerance		Inductance
DRB20									
		Fixed Resistance	8W	8W	10R	10 Ω	F	$\pm 1\%$	N Inductance
			20W	20W	110R	110 Ω	J	$\pm 5\%$	
		T Adjustable Resistance	100W	100W	1K1	1.1K Ω	K	$\pm 10\%$	
			500W	500W	10K	10K Ω			



► General Information

General Purpose Resistors with Customized Service

Token Electronics is expanding business to include a broad range of General Purpose Resistor products designed for high volume applications. This expanded range of commercial resistor presents a more comprehensive product offering for Customer Experience Management (CEM) and other high volume customers that require quality products at competitive pricing.

Backed by the same customer service, technical support and quality assurance that Token has always provided, these new commercial products enable you the opportunity to source a wider range of resistors from a trusted supplier.

General Use

When an ambient temperature exceeds a rated ambient temperature, resistor shall be applied on the derating curve by derating the load power. General purpose resistor under overloads is not combustion resistant and is likely to emit, flame, gas, smoke, red heat, etc. Flame retardant resistor generally emits smoke and red heat in a certain power and over but do not emit fire or flame.

When resistors are shielded or coated with resin etc., stress from the storage heat and the resins are applied. So, performance and reliability should be checked well before use.

When a voltage higher than rated is applied in a short time (single pulse, repeated pulses, surge, etc.), it does not necessarily ensure safety that an effective wattage is not higher than a rated wattage. Then consult with us with your specified pulse wave shape. Resistors shall be used in a condition causing no dew condensation.

Keep temperature from rising by choosing resistor with a higher rated capacity; do not use a component having the exact load value required. For considerations of safety in extended period applications, the rating should be more than four times higher than the actual wattage involved, but never use resistors at less than 25% of its rated power.

In applications where resistors are subject to intermittent current surges and spikes, be sure in advance that the components selected are capable of withstanding brief durations of increased load.

Do not exceed the recommended rated load. Resistor must use within the rated voltage range to prevent the shortening of service life and/or failure of the wound resistance elements.

Minimum load: Resistor must be utilized at 1/10 or more of the rated voltage to prevent poor conductance due to oxidation build-up. For basic particulars for cautions, refer to EIAJ Technical Report RCR-2121 "Guidance for care note on fixed-resistors".

