

Power Wirewound Resistor Assembly Method

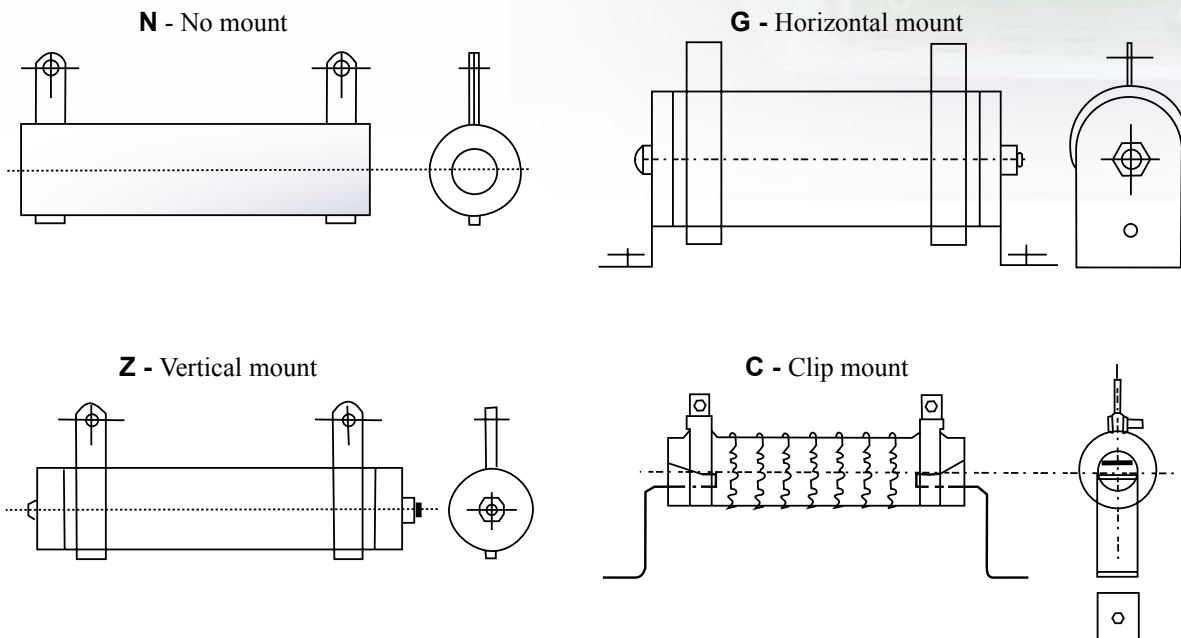

▶ Power Wirewound Resistor Order Codes Example

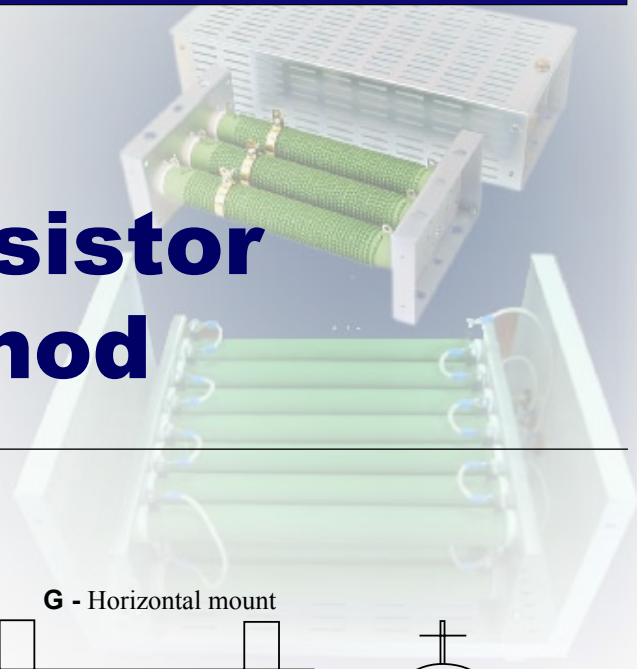
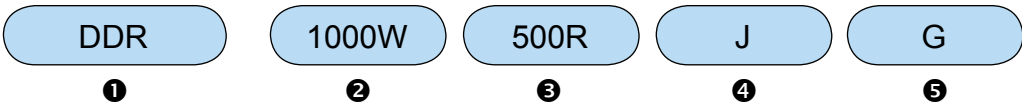

- ❶ Part Number: DDR, DCR
- ❷ Rated Power (W): 10W~1300W, 100W~250W
- ❸ Resistance Value (Ω): Indicates resistance value in units of ohms.
- ❹ Resistance Tolerance (%)
- ❺ Assembly Method

Code	Resistance Tolerance
J	$\pm 5\%$
K	$\pm 10\%$

Code	Resistance Tolerance
N	No mount.
C	Clip mount.
G	Horizontal mount.
Z	Vertical mount.

[Back to 1st Page - Wirewound Power Resistors \(Assembly Method\)](#)

