

Version:  
December 1, 2022



# **(PT-IC-AC) Visible Light Sensor RoHS Compliant**

**Web: [www.token.com.tw](http://www.token.com.tw)**

**Email: [rfq@token.com.tw](mailto:rfq@token.com.tw)**

**Token Electronics Industry Co., Ltd.**

**Taiwan: No.137, Sec. 1, Zhongxing Rd., Wugu District,  
New Taipei City, Taiwan. 248012**

**Tel: +886 2981 0109 Fax: +886 2988 7487**

**China: 17P, Nanyuan Maple Leaf Bldg., Nanshan Ave.,  
Nanshan Dist., Shenzhen, Guangdong, China. 518054  
Tel: +86 755 26055363**



## ▶ Product Introduction

**Token providing optimized light sensing solutions to enhance system efficiency and ease-of-design.**

### Features :

- Simulate the human eye, peak wavelength 550nm.
- Built-in infrared filter, can be anti-infrared interference.
- Good batch consistency, completely solve the infrared light start too early.
- Fast response, stable performance, aging at +85°C/ 65% humidity for 1000 Hr.
- The starting point does not drift. Nice appearance.

### Applications :

- Replace the traditional CDS photoresistor.
- Cadmium and lead free with RoHS compliant.
- Dedicated to infrared monitoring products.
- When control the infrared light, it is no need to add extra casing and filter on low illumination.

### Customization :

- For the convenience of installation in all kinds of products in any position, different sizes are available upon request.
- Token offers various option of the bright current/dark current (bright resistance/dark resistance) to costume the most products.

(PT-IC-AC) visible light sensor is a silicon NPN epitaxial planar phototransistor in a T-1 package. It is sensitive to visible light much like the human eye and has peak sensitivity at 520nm ~ 580nm.

The spectral response of the integrated light sensor with a very low dark current that are optimized for sensing low level light signals. So it ignores light such as infrared which emits energy but does not aid vision. This eliminates the need for an Infrared filter required with competitor light sensors.

The (PT-IC-AC) Plate Edge IR visible light detector using high quality chip packaging and processing super-plated infrared filter membrane on chip surface, so this sensor can fully filter infrared interference. It is no need to add the casing and extra filter and effective filtering out the effect of light reflection due to infrared emission on security products.

By selecting the accuracy of chips, under strict management of production process, (PT-IC-AC) visible light sensors finished batch consistency uniform. The consistency is 3 to 5 times higher on comparison of similar photosensitive devices. The precision can be controlled as narrow as 10%. Fully meet the customer requirements for starting the LUX value. Token taking the advantage of temperature compensation internal process on the chip, (PT-IC-AC) features one times higher temperature resistance than other similar products while working on high temperature environment. Please contact our sales or link to Token official website "[Visible Light Sensors](http://www.token.com.tw)" for more information.



## ► Dimensions

### Dimensions & Configurations (Unit: mm) (PT-IC-AC-PE-550) Plate Edge

Part NO.	A (mm)	B (mm)	C (mm)	D (mm)	E (mm)	F (mm)	G (mm)	H (mm)	I (mm)
PT-IC-AC-3-PE-550	4.05 ± 0.20	3.00 ± 0.20	1.50 Max.	1.50 ± 0.5	2.54 ± 0.20	3.85 ± 0.20	0.75 ± 0.20	25.4 Min.	0.50 ± 0.20
PT-IC-AC-5-PE-550	5.80 ± 0.20	5.00 ± 0.20	1.50 Max.	1.50 ± 0.50	2.54 ± 0.20	5.30 ± 0.20	1.00 ± 0.20	25.4 Min.	0.50 ± 0.50

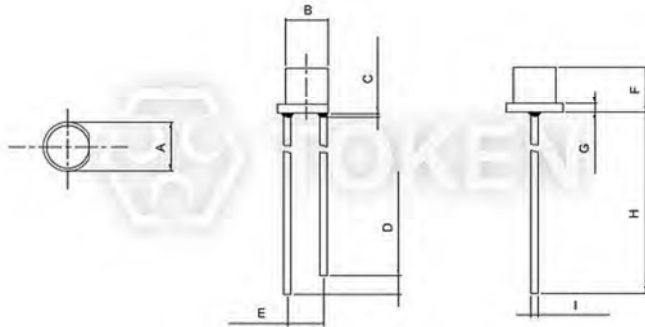

Visible Light Sensor RoHS Compliant (PT-IC-AC-PE-550) Dimensions



Visible Light Sensor RoHS Compliant (PT-IC-AC-PE-550)

**Remark:**

- The epoxy resin highest: 1.5mm max.
- Product images, plastic color of appearance, and all other information is for reference only, goods in-kind prevail.
- Short Lead—Collector    Long Lead—Emitter.

### Dimensions & Configurations (Unit: mm) (PT-IC-AC-5-BN-520) Bullet None

Part NO.	A (mm)	B (mm)	C (mm)	D (mm)	E (mm)	F (mm)	G (mm)	H (mm)
PT-IC-AC-5-BN-520	5.00 ± 0.20	5.00 ± 0.20	1.50 Max.	2.00 ± 0.5	2.54 ± 0.20	7.00 ± 0.20	14.00 Min.	0.50 ± 0.20

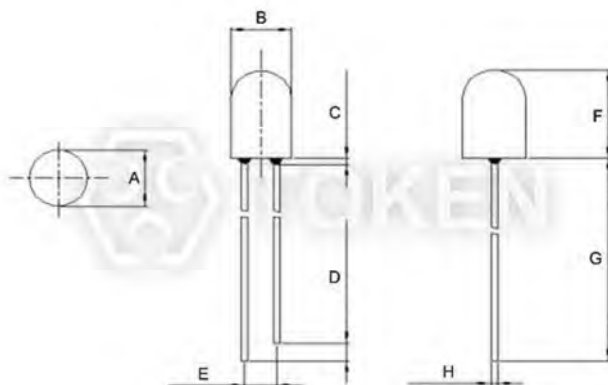

Visible Light Sensor RoHS Compliant (PT-IC-AC-5-BN-520) Dimensions



Visible Light Sensor RoHS Compliant (PT-IC-AC-5-PN-580)

**Remark:**

- The epoxy resin highest: 1.5mm max.
- Product images, plastic color of appearance, and all other information is for reference only, goods in-kind prevail.
- Short Lead—Collector    Long Lead—Emitter.

**Dimensions & Configurations (Unit: mm) (PT-IC-AC-5-PN-580) Plate None**

Part NO.	A (mm)	B (mm)	C (mm)	D (mm)	E (mm)	F (mm)
PT-IC-AC-5-PN-580	5.00 ± 0.20	5.00 ± 0.20	5.30 ± 0.20	14.0 Min.	2.00 ± 0.50	2.54 ± 0.20

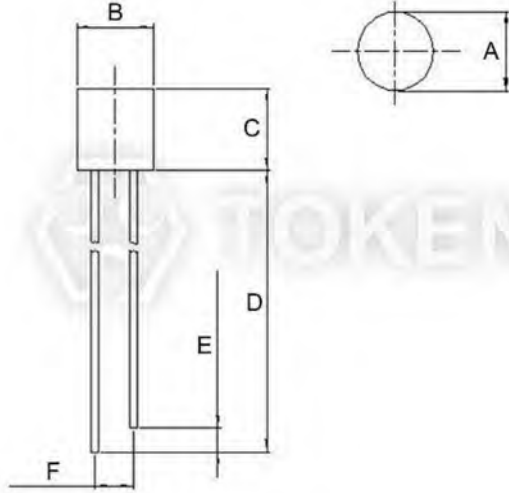

Visible Light Sensor RoHS Compliant (PT-IC-AC-5-PN-580) Dimensions



Visible Light Sensor RoHS Compliant  
(PT-IC-AC-5-PN-580)

**Remark:**

- The epoxy resin highest: 1.5mm max.
- Product images, plastic color of appearance, and all other information is for reference only, goods in-kind prevail.
- Short Lead—Collector    Long Lead—Emitter.

► PE Electro-Optical

**Electro-Optical Characteristics (Ta=25 °C) (PT-IC-AC-3-PE-550) Plate Edge**

Parameter	Symbol	Condition	Min.	Typ.	Max.	Unit
Peak Wavelength	$\lambda_p$	\	-	550	-	nm
Spectral Response Range	$\lambda$	\	400	-	-	nm
Operating Voltage	$V_{cc}$	\	-	5	-	V
Photo Current	$I_{L(1)}$	$V_{cc}=5V$ $E_v=10Lux$	7	13	18	$\mu A$
	$I_{L(2)}$	$V_{cc}=5V$ $E_v=30Lux$	21	39	54	$\mu A$
	$I_{L(3)}$	$V_{cc}=5V$ $E_v=100Lux$	70	130	180	$\mu A$
Collector Dark Current	$I_d$	$V_{cc}=5V/85^\circ C$ $E_v=0Lux$	-	-	0.8	$\mu A$
Rise Time	$t_r$	$V_{cc}=5V$ $E_v=30Lux$	4.5			ms
Fall Time	$t_f$	$RL=1000\Omega$	4.5			

**Electro-Optical Characteristics (Ta=25 °C) (PT-IC-AC-5-PE-550) Plate Edge**

Parameter	Symbol	Condition	Min.	Typ.	Max.	Unit
Peak Wavelength	$\lambda_p$	\	-	550	-	nm
Spectral Response Range	$\lambda$	\	400	-	-	nm
Operating Voltage	$V_{cc}$	\	-	5	-	V
Photo Current	$I_{L(1)}$	$V_{cc}=5V$ $E_v=10Lux$	7	13	18	$\mu A$
	$I_{L(2)}$	$V_{cc}=5V$ $E_v=30Lux$	20	39	54	$\mu A$
	$I_{L(3)}$	$V_{cc}=5V$ $E_v=100Lux$	70	130	180	$\mu A$
Collector Dark Current	$I_d$	$V_{cc}=5V/85^\circ C$ $E_v=0Lux$	-	-	0.8	$\mu A$
Rise Time	$t_r$	$V_{cc}=5V$ $E_v=30Lux$	4.5			ms
Fall Time	$t_f$	$RL=1000\Omega$	4.5			

**Absolute maximum ratings (Ta=25 °C) (PT-IC-AC-3-PE-550) & (PT-IC-AC-5-PE-550) Plate Edge**

Parameter	Symbol	Value		Unit
		Min.	Max.	
Operating Voltage	$V_{cc}$			V
		1	10	V
Power Dissipation	$P_c$	70		$m^W$
Operating Temperature Range	$T_{opr}$	-25 ~ +85		$^\circ C$
Storage Temperature	$T_{stg}$	-40 ~ +100		$^\circ C$

▶ **BN Electro-Optical**

**Electro-Optical Characteristics (Ta=25 °C) (PT-IC-AC-5-BN-520) Bullet None**

Parameter	Symbol	Condition	Min.	Typ.	Max.	Unit
Peak Wavelength	$\lambda_p$	\	-	520	-	nm
Spectral Response Bandwidth	$\lambda$	\	400	-	700	nm
Operating Voltage	$V_{cc}$	\	-	5	-	V
Photo Current	$I_{L(1)}$	$V_{cc}=5V$ $E_v=10L_{ux}$	4	8	12	$\mu A$
	$I_{L(2)}$	$V_{cc}=5V$ $E_v=30L_{ux}$	12	24	36	$\mu A$
	$I_{L(3)}$	$V_{cc}=5V$ $E_v=100L_{ux}$	40	80	120	$\mu A$
Collector Dark Current	$I_d$	$V_{cc}=5V/85^\circ C$ $E_v=0L_{ux}$	-	-	0.8	$\mu A$
IR Receiving Current	$I_{L(4)}$	$V_{cc}=5V/850nm$ IR LED $E_e=1m^W/cm^2$	-	-	0.05	$\mu A$
Rise Time	$t_r$	$V_{cc}=5V$	4.5			ms
Fall Time	$t_f$	$RL=1000\Omega$	4.5			

**Absolute maximum ratings (Ta=25 °C) (PT-IC-AC-5-BN-520) Bullet None**

Parameter	Symbol	Value	Unit
Collector-Emitter Breakdown Voltage	$V_{CEO}$	60	V
Emitter-Base Breakdown Voltage	$V_{ECO}$	7	V
Power Dissipation	$P_C$	50	$m^W$
Operating Temperature Range	$T_{opr}$	-25 ~ +85	$^\circ C$
Storage Temperature	$T_{stg}$	-40 ~ +100	$^\circ C$



## ▶ PN Electro-Optical

### Electro-Optical Characteristics (Ta=25 °C) (PT-IC-AC-5-PN-580) Plate None

Parameter	Symbol	Condition	Min.	Typ.	Max.	Unit
Peak Wavelength	$\lambda_p$	\	-	580	-	nm
Spectral Response Bandwidth	$\lambda$	\	400	-	700	nm
Operating Voltage	$V_{cc}$	\	-	5	-	V
Photo Current	$I_{L(1)}$	$V_{cc}=5V$ $E_v=10L_{ux}$	1.5	3.5	5.5	$\mu A$
	$I_{L(2)}$	$V_{cc}=5V$ $E_v=30L_{ux}$	4.5	10.5	16.5	$\mu A$
	$I_{L(3)}$	$V_{cc}=5V$ $E_v=100L_{ux}$	15	35	55	$\mu A$
Collector Dark Current	$I_D$	$V_{cc}=5V/85^\circ C$ $E_v=0L_{ux}$	-	-	0.8	$\mu A$
IR Receiving Current	$I_{L(4)}$	$V_{cc}=5V/850nm$ ir LED $E_c=1m^W/cm^2$	-	-	0.05	$\mu A$
Rise Time	$t_r$	$V_{cc}=5V$	4.5			ms
Fall Time	$t_f$	RL=1000 $\Omega$	4.5			

### Absolute maximum ratings (Ta=25 °C) (PT-IC-AC-5-PN-580) Plate None

Parameter	Symbol	Value		Unit
		Min.	Max.	
Operating Voltage	$V_{cc}$	Min.	Max.	V
		1	10	V
Operating Temperature Range	$T_{opr}$	-25 ~ +85		$^\circ C$
Storage Temperature	$T_{stg}$	-40 ~ +100		$^\circ C$
Soldering Temperature	$T_{sol}$	260		$^\circ C$

▶ 3-PE Curve

Relative Spectral Sensitivity vs. Wavelength (PT-IC-AC-3-PE-550)

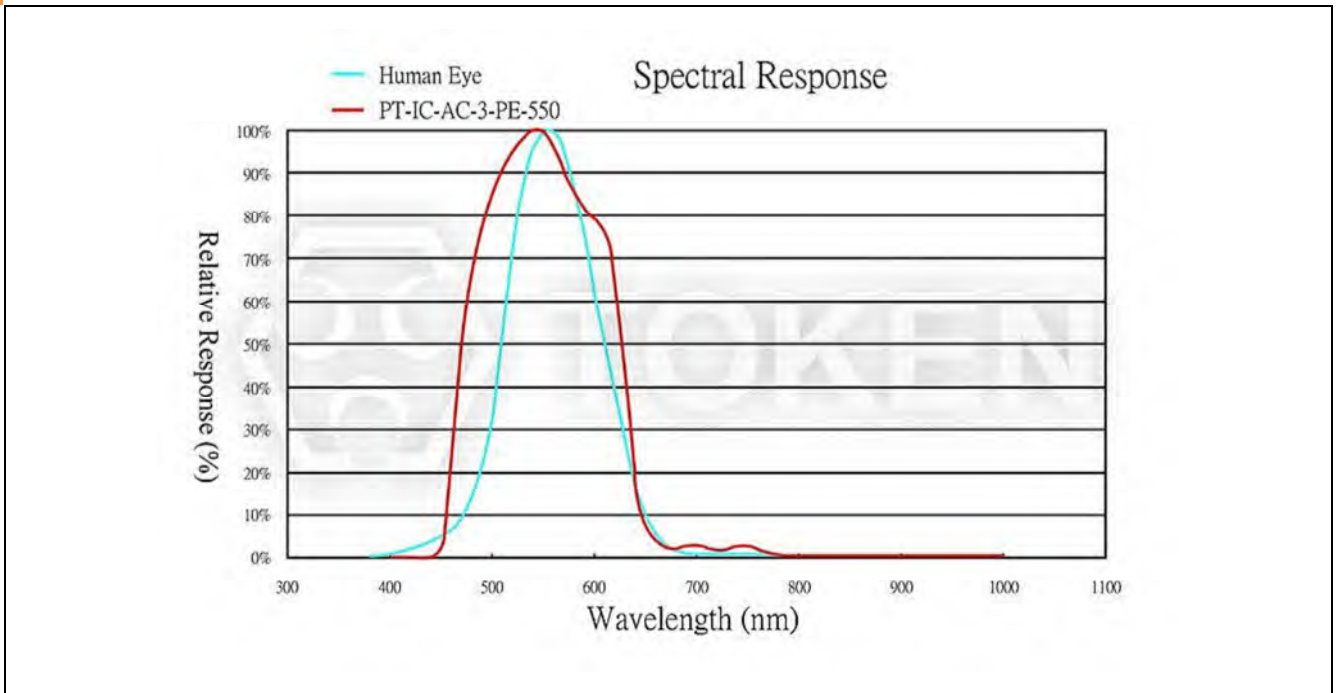
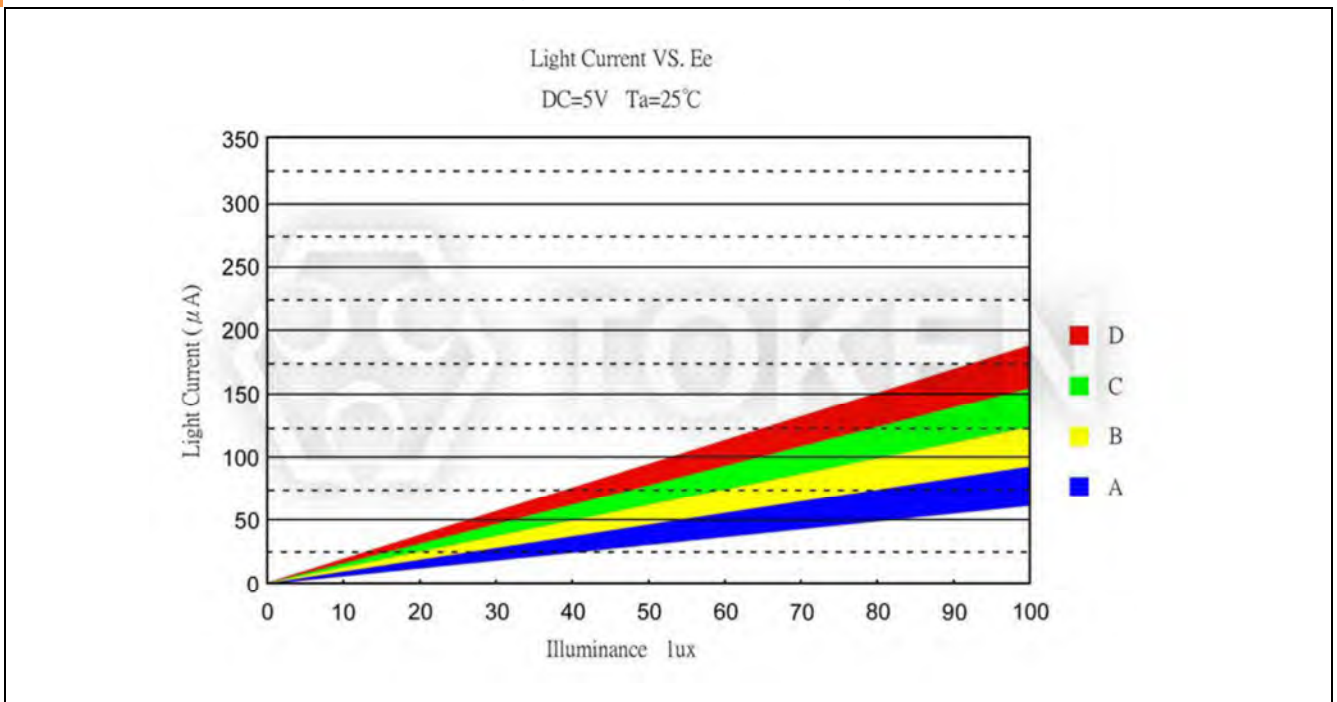
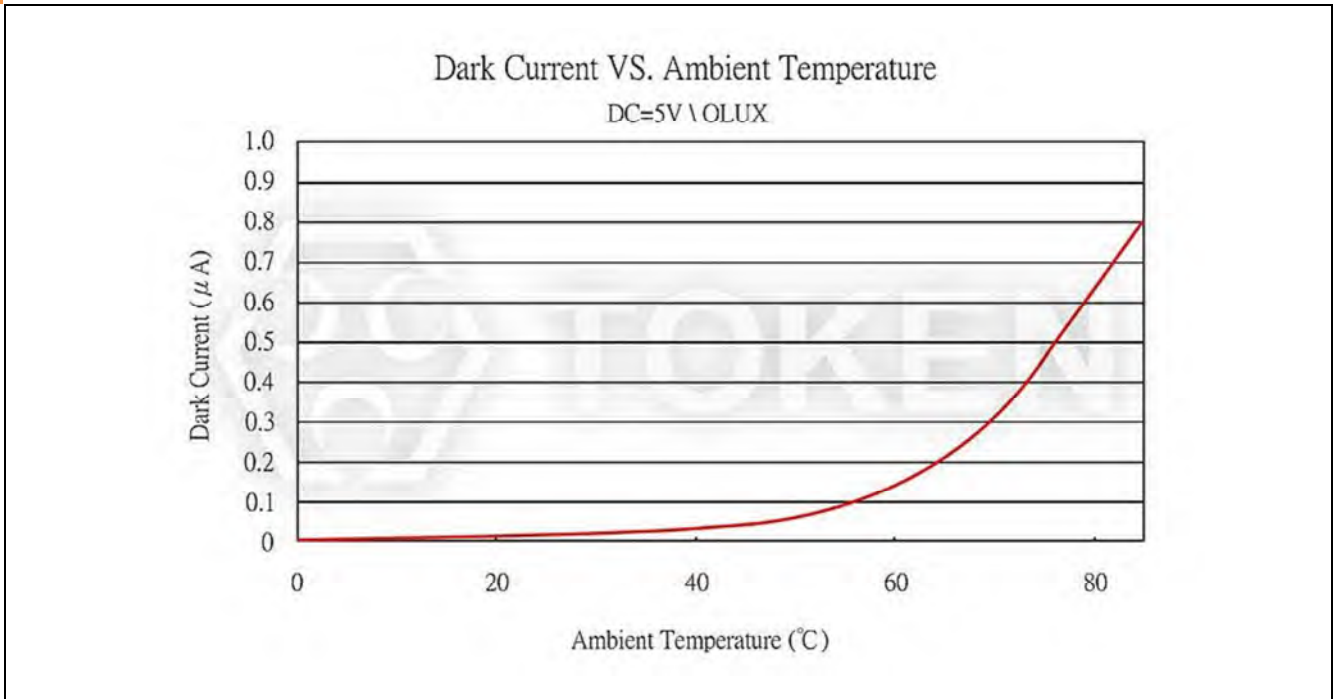

Photo Current vs. Illuminance (PT-IC-AC-3-PE-550)





Dark Current vs. Ambient Temperature (PT-IC-AC-3-PE-550)



► 5-PE Curve

Relative Spectral Sensitivity vs. Wavelength (PT-IC-AC-5-PE-550)

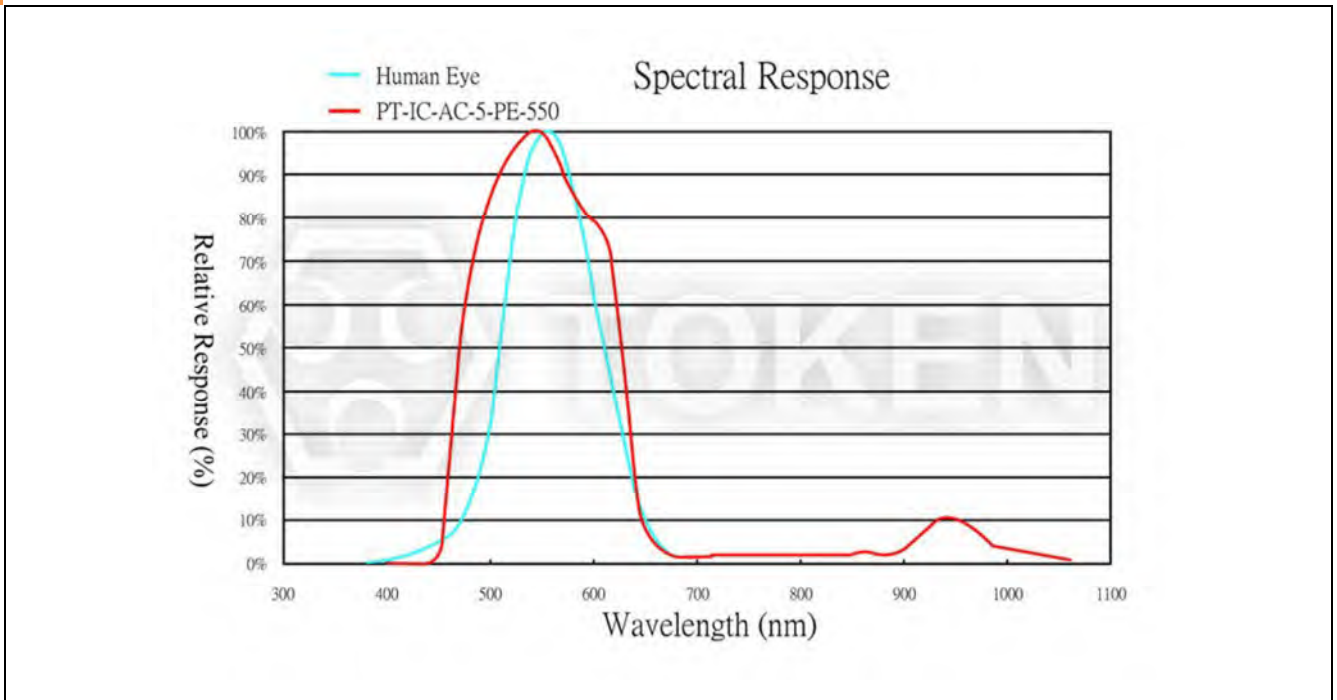
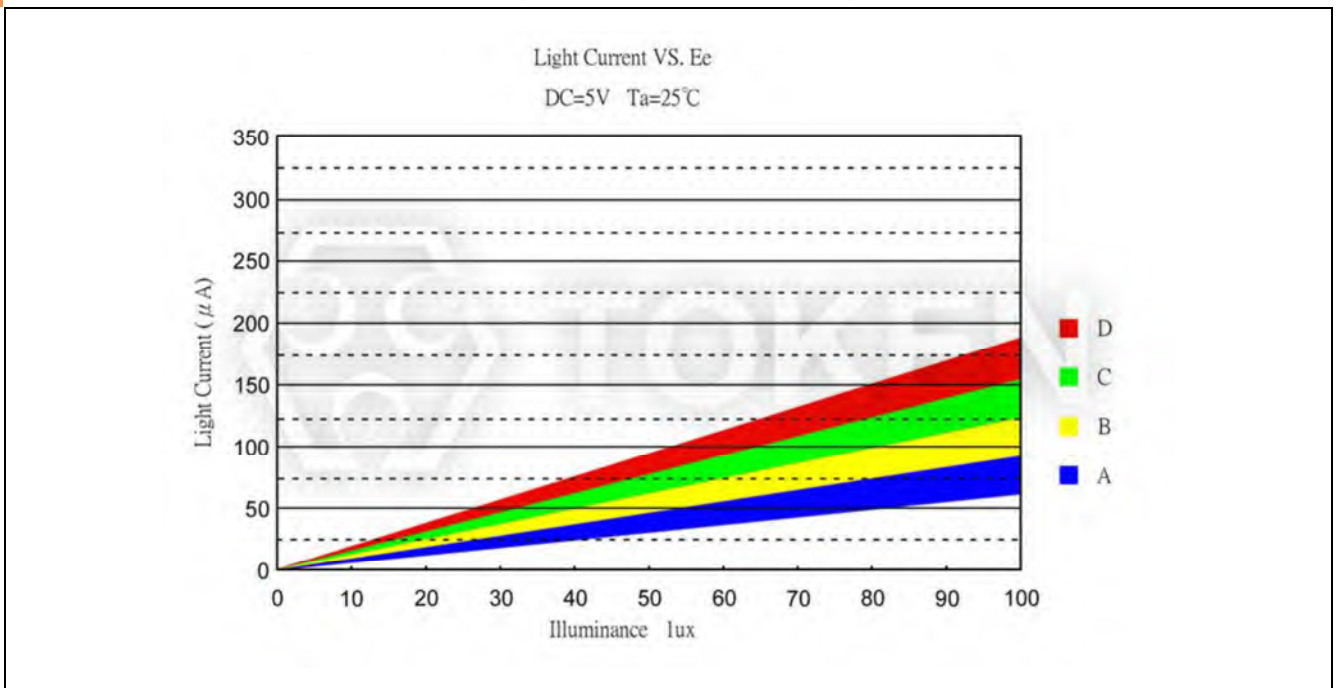
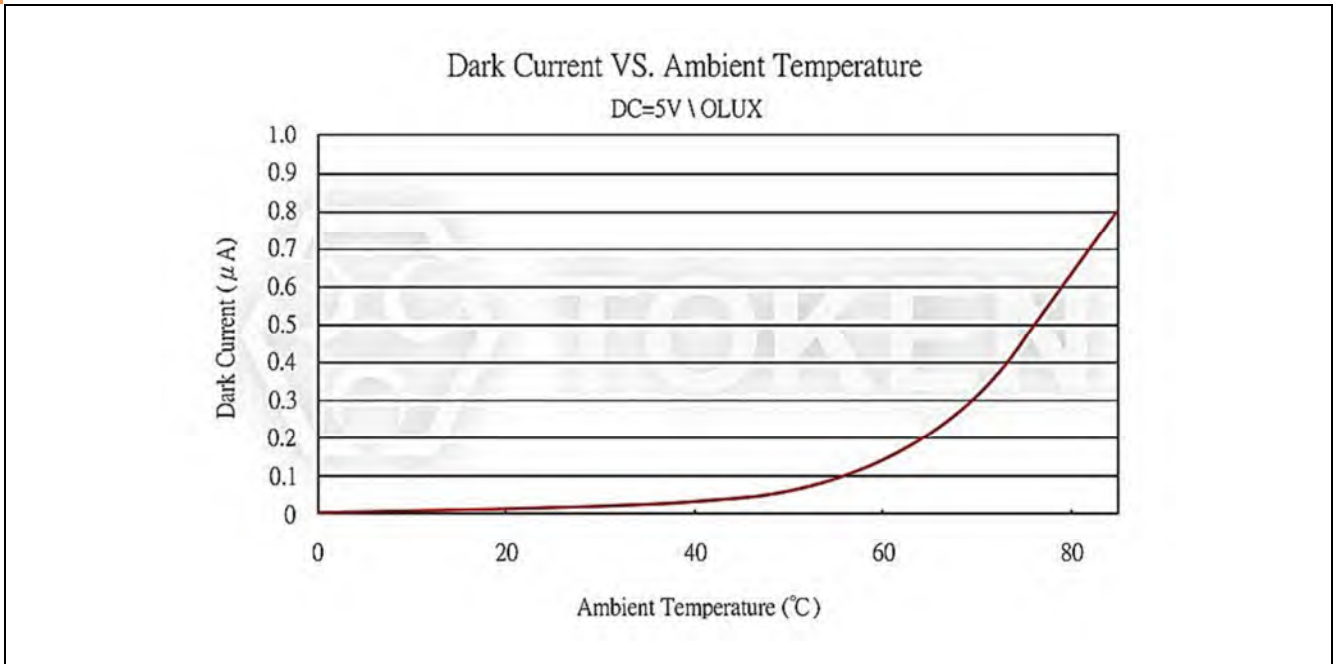

Photo Current vs. Illuminance (PT-IC-AC-5-PE-550)



Dark Current vs. Ambient Temperature (PT-IC-AC-5-PE-550)



▶ **BN Curve**

**Relative Spectral Sensitivity vs. Wavelength (PT-IC-AC-5-BN-520)**

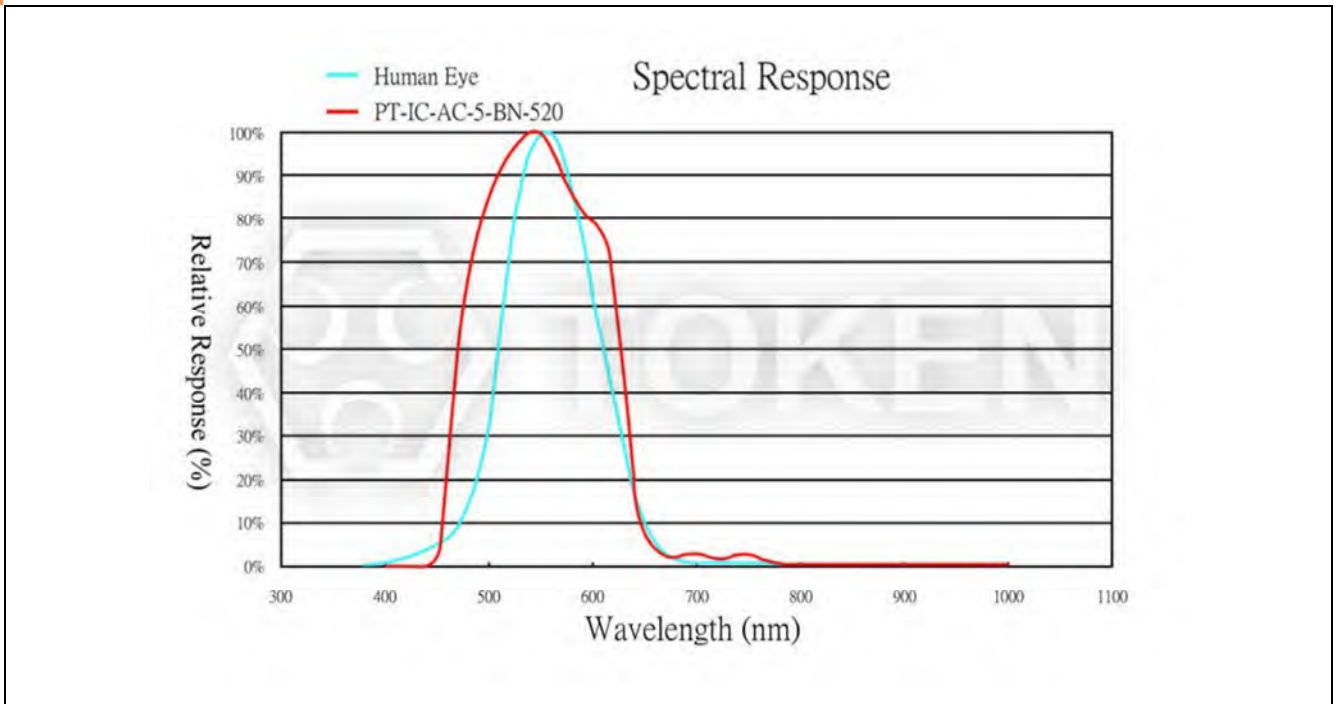

**Photo Current vs. Illuminance (PT-IC-AC-5-BN-520)**

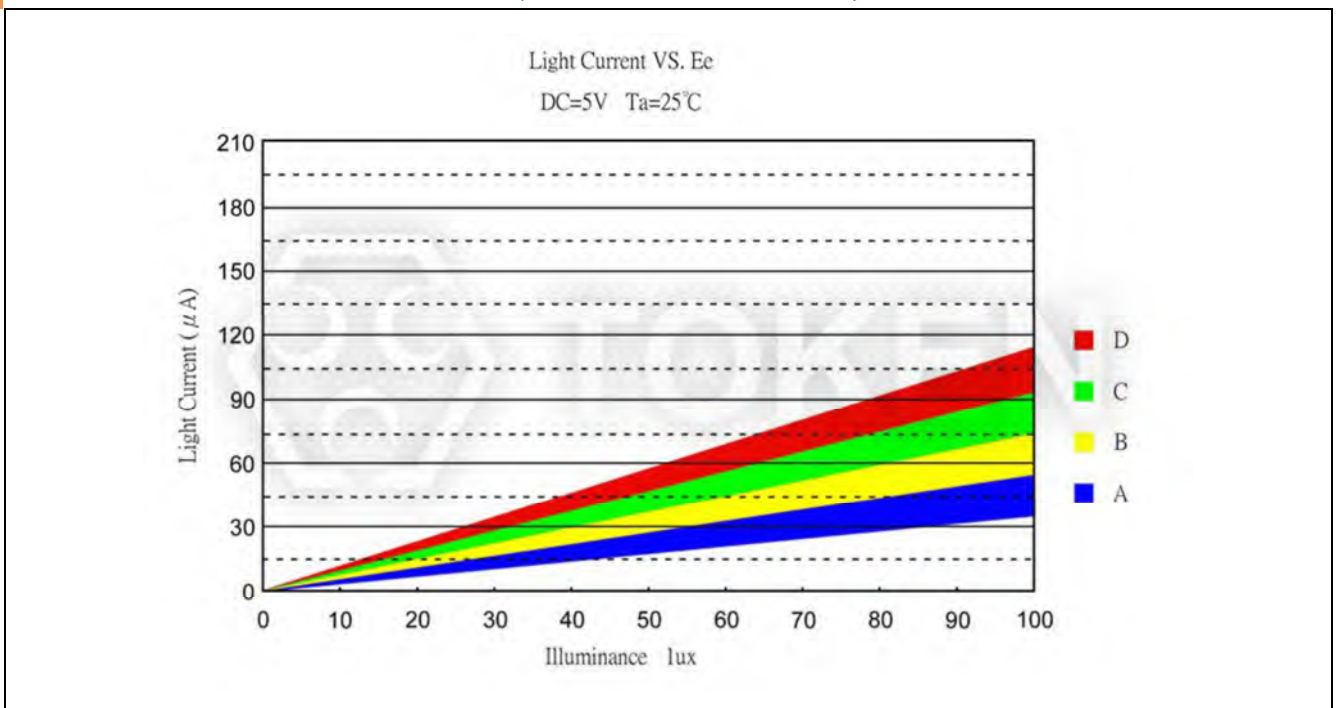

Dark Current vs. Ambient Temperature (PT-IC-AC-5-BN-520)

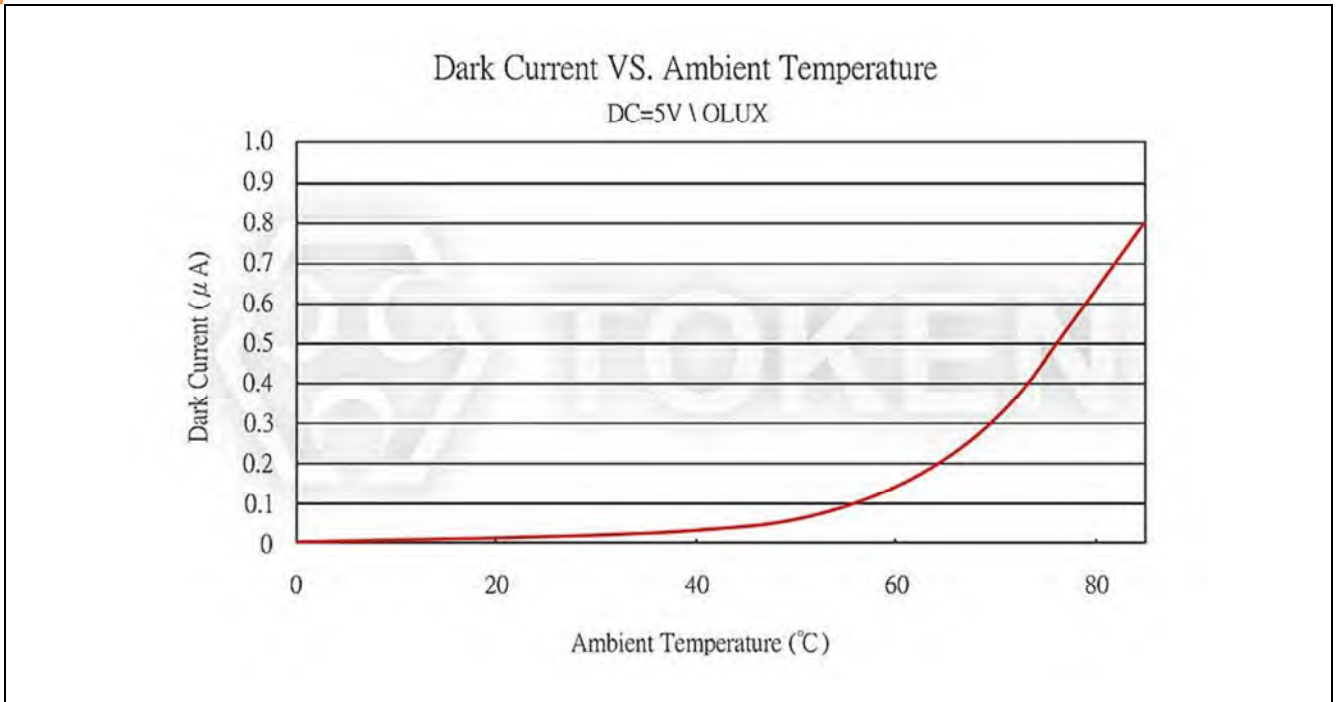

▶ PN Curve

Relative Spectral Sensitivity vs. Wavelength (PT-IC-AC-5-PN-580)

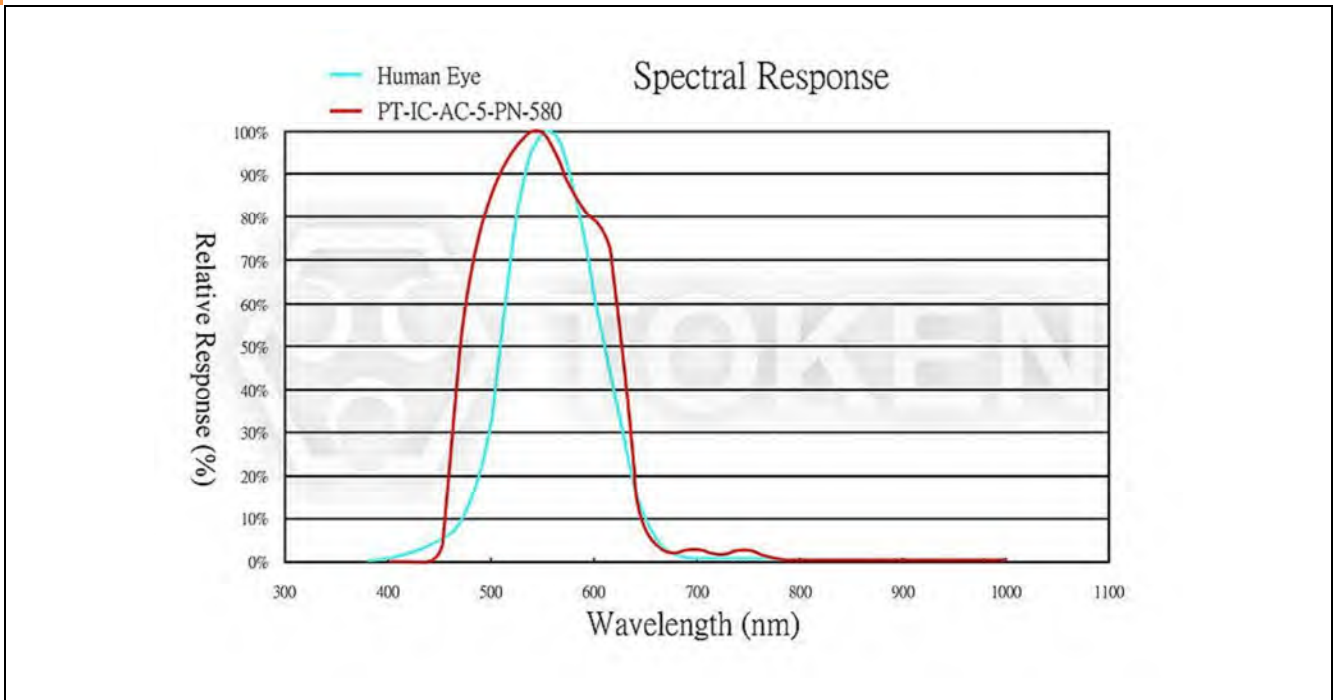
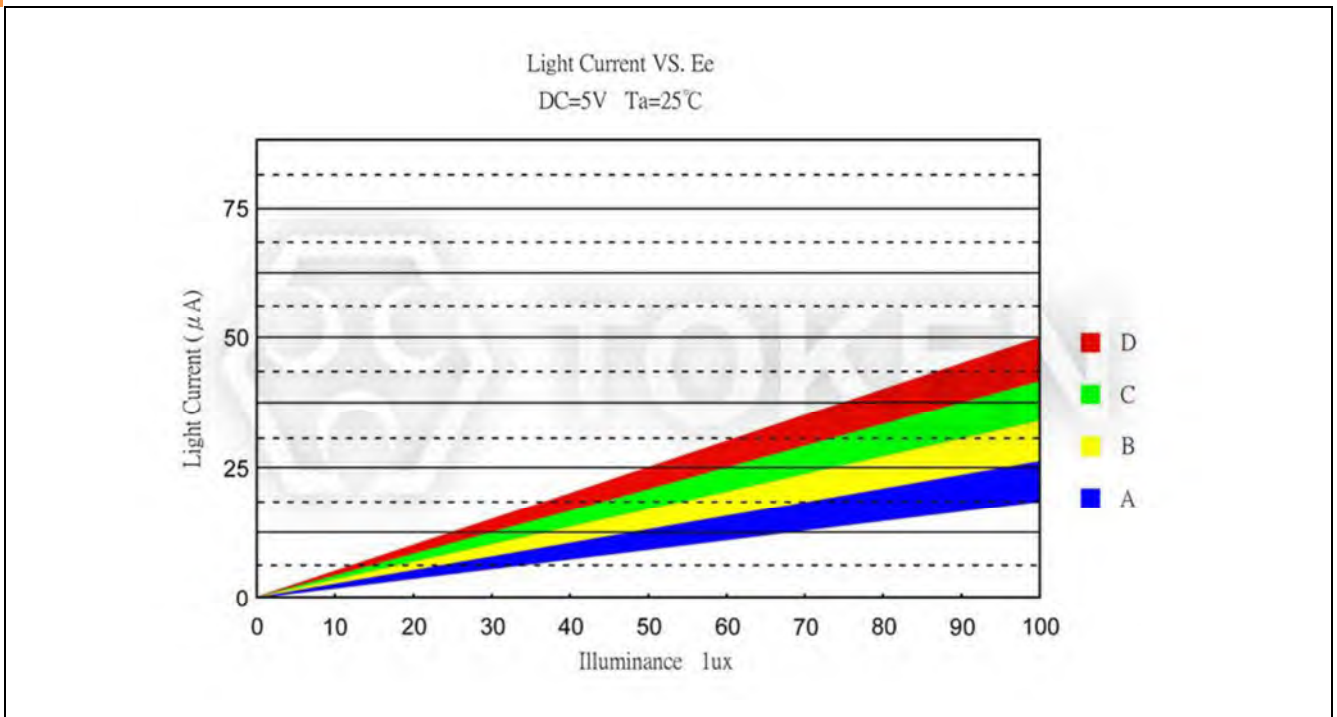
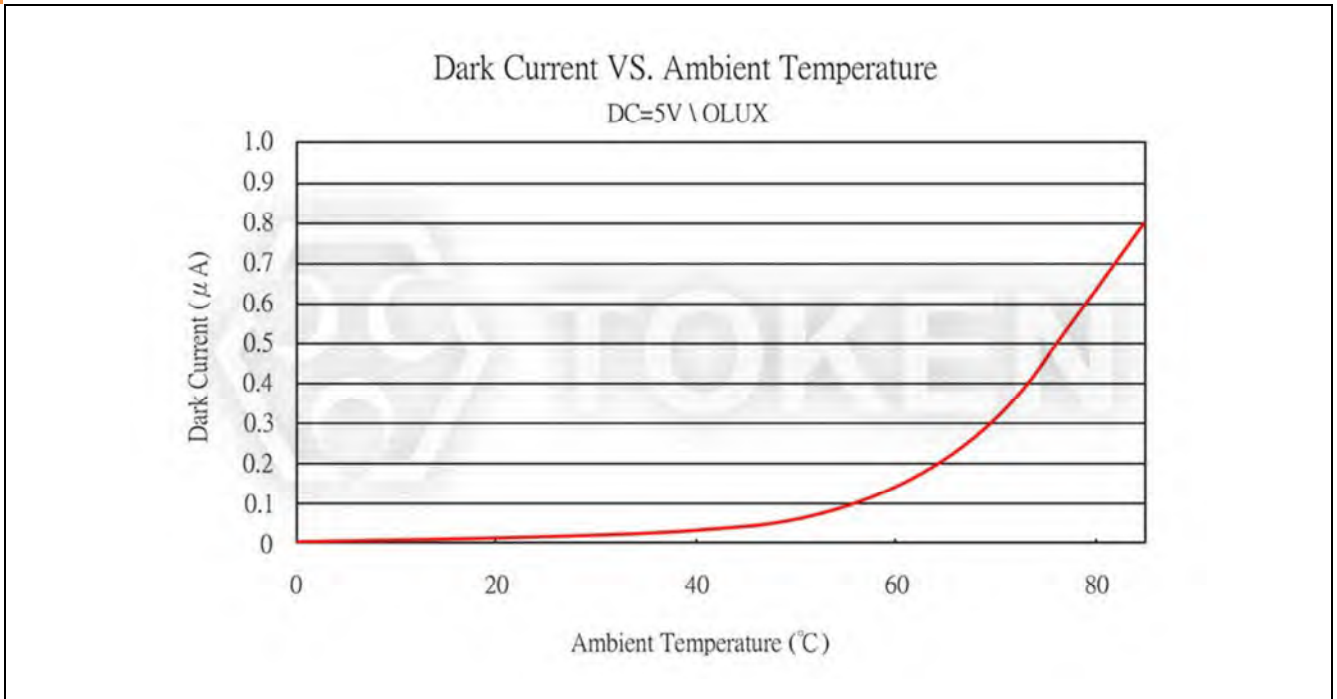

Photo Current vs. Illuminance (PT-IC-AC-5-PN-580)



Dark Current vs. Ambient Temperature (PT-IC-AC-5-PN-580)



► **Note**

**Visible Light Detector (PT-IC-AC) Precaution Usage :**

- The light source : Select 590nm LED Surface light source.

**Mounting :**

- While packages are on one circuit board, avoid mismatching in the thermal expansion of each component, generate cracks in the package and break the bonding wire.

**Soldering :**

- Do not immerse plastic parts in tin tank.
- During soldering, when adding thermal stress in a moisture absorbing state, moisture evaporates, swells and generates stress to the internal package.
- To avoid swellings and cracks in the surface of the package, followsoldering conditions below.
- Wave soldering method: 120°C < 60s 、 260°C < 5s.
- Manual soldering: 260°C < 5s 、 340°C < 3s.

**Lead-forming and cuttings :**

- Before soldering, perform lead forming at normal temperature.
- While forming or cutting the lead, stay the area at a distance of 5 mm or greater from the root of the lead.
- Avoid mounting which may cause force on the root of the lead.

**Storage :**

The sensor is incorporated in the transparent resin package. Because of its sensitivity to humidity, the package is moisture-proof. When storing the sensor, do as instructed below.

- Quickly use after opening. (within 2 days, below 30 °C/60 % R.H.).
- Once unpacked, use within three months, or keeping within a moisture-proof method, which include maintaining within a moisture-proof container with silica gels, is suggested for longterm safe-keeping.
- Very bad storage conditions may deteriorate solderability or characteristics, and defect the appearance. Recommended conditions of the storage place, temperature 0°C to 30 °C, humidity below 60% R.H. (Avoid freezingand dew condensation).

**Cleaning :**

- Do not wash with water to avoid corrosion.
- Under any circumstance, the cleaning time should be within 1 minute of normal temperature.
- Alcohol is recommended as a cleaning agent when cleaning products.
- If you use other cleaning agents, you need to confirm whether the cleaning agent will corrode the epoxy body.
- Freon can not be used as a cleaning agent.
- When cleaning products with ultrasonic cleaning, ultrasonic power and time should be less than 300W and 30 seconds, respectively.
- PCB and product can not touch the oscillator. Can not make the product on the PCB resonance.
- This model is static sensitive devices, so static electricity and surges can damage the product.
- To all the equipment, machines, tables, and the ground must be anti-static ground.
- Requires the use of anti-static wrist strap wear.

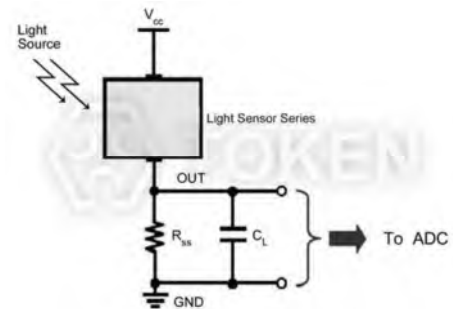

Photo Current Measurement Method - (PT-IC-AC)



▶ **Order Codes**

**Order Codes (PT-IC-AC)**

PT	-	IC	-	AC	-	3	-	PE	-	550
Part Number		Chip Type		Lens Color		Size		Shape		Spectral Bandwidth
PT		IC		AC      Water Clear		3      3 mm		PE      Plate Edge		520      520 nm
						5      5 mm		BN      Bullet None		550      550 nm
								PN      Plate None		580      580 nm