

# Inductors Glossary

## A - C

### Air Core Inductors

(see Ceramic Core and Phenolic Core)

### Ambient Temperature

The temperature of still air immediately surrounding a component or circuit. A typical method to measure ambient temperature is to record the temperature that is approximately 1/2 inch from the body of the component or circuit.

### Attenuation

The relative decrease in amplitude of a given parameter. Attenuation measurements are common for voltage, current and power. It is usually expressed in units of decibels (dB). For a power ratio, one dB =  $10 \text{ Log}_{10} (P_1/P_2)$ . A dB is equal to  $20 \text{ Log}_{10} (I_1/I_2)$  for current and  $20 \text{ Log}_{10} (V_1/V_2)$  for voltage ratios.

### Axial Inductor

An inductor constructed on a core with concentric leads on opposite ends of the core. Axial inductors are available for both power applications and RF applications, and are available in many core materials including the basic phenolic, ferrite and powdered iron types. Both rod and bobbin shapes are utilized. Axial inductors are very suitable for tape and reel packaging for auto placement. (see Inductor).



**Axial Leaded Inductor**

### Bobbin Core

A core with the shape of a bobbin or spool which contains flanges. Bobbin cores are available with and without leads and in the axial and radial form. (see Axial Inductor and Radial Inductor)



**Axial Leaded**

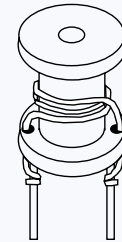

**Radial Leaded**

### Boost Regulator (DC-DC)

A basic DC-DC switching converter topology that takes an unregulated input voltage, and produces a higher, regulated output voltage. This higher output voltage is achieved by storing energy in an input inductor and then transferring the energy to the output by turning a shunt switch (transistor) on and off.

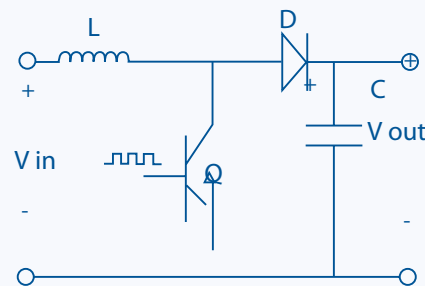

**Simplified Boost Regulator**

## Buck Regulator (DC-DC)

A basic DC-DC switching converter topology that takes an unregulated input voltage, and produces a lower, regulated output voltage. This output voltage is achieved by chopping the input voltage with a series connected switch (transistor) which applies pulses to an averaging inductor and capacitor circuit.

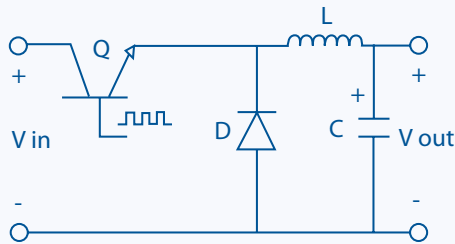

**Simplified Buck Regulator**

## Ceramic Cores

Ceramic is one of the common materials used for inductor cores. Its main purpose is to provide a form for the coil. In some designs it also provides the structure to hold the terminals in place. Ceramic has a very low thermal coefficient of expansion. This allows for relatively high inductance stability over the operating temperature ranges.

Ceramic has no magnetic properties. Thus, there is no increase in permeability due to the core material. Ceramic core inductors are often referred to as “air core” inductors.

Ceramic core inductors are most often used in high frequency applications where low inductance values, very low core losses and high  $Q$  values are required.

## Choke

(see RF Choke)

## Closed Magnetic Path

Magnetic core shapes designed to contain all of the magnetic flux generated from an excited winding(s). Inductors made with these core types are considered to be shielded inductors. Shielding, however, is a matter of degree. Common core shapes that are considered to have closed magnetic paths are toroids, E-cores and most pot cores. Shielded bobbins also offer a high degree of shielding and may be considered to have closed magnetic paths for most practical purposes. Common core shapes that are considered to have open magnetic flux paths are rod cores and unshielded bobbin cores. (see Shielded Inductor)

## Coils

Another common name for inductors. (see Inductor)

## Color Codes

Inductor color codes have been standardized. The color marks or bands represent the inductor’s value and tolerance. There is a page that translates the colors and numbers, see Inductor Color Code Marking System.

## Common-Mode Noise

Noise or electrical interference that is common to both electrical lines in relation to earth ground.

## Copper Loss

The power lost by current flowing through the winding. The power loss is equal to the square of the current multiplied by the resistance of the wire ( $I^2R$ ). This power loss is transferred into heat.

## D - G

### Core Losses

Core losses are caused by an alternating magnetic field in the core material. The losses are a function of the operating frequency and the total magnetic flux swing. The total core losses are made up of three main components: Hysteresis, eddy current and residual losses. These losses vary considerably from one magnetic material to another. Applications such as higher power and higher frequency switching regulators and RF designs require careful core selection to yield the highest inductor performance by keeping the core losses to a minimum.

### Core Saturation

(see Saturation Current)

### Curie Temperature

The temperature above which a ferrite core loses its magnetic properties. The core's permeability typically increases dramatically as the core temperature approaches the curie temperature which causes the inductance to increase. The permeability drops to near unity at the curie temperature which causes the inductance to drop dramatically. The curie point is the temperature at which the initial permeability has dropped to 10% of its original value at room temperature.

### DC-DC Converter

A circuit or device that converts a DC input voltage to a regulated output voltage. The output voltage may be lower, higher or the same as the input voltage. Switching regulator DC-DC circuits most often require an inductor or transformer to achieve the regulated output voltage. Switching regulator circuits can achieve a higher level of power efficiency when compared to non-switching techniques. (see Boost Regulator and Buck Regulator)

### DCR (DC Resistance)

The resistance of the inductor winding measured with no alternating current. The DCR is most often minimized in the design of an inductor. The unit of measure is ohms, and it is usually specified as a maximum rating.

### Differential-Mode Noise

Also known as normal-mode noise, it is electrical interference that is not common to both electrical lines but present between both electrical lines.

### Distributed Capacitance

In the construction of an inductor, each turn of wire or conductor acts as a capacitor plate. The combined effects of each turn can be represented as a single capacitance known as the distributed capacitance. This capacitance is in parallel with the inductor. This parallel combination will resonate at some frequency which is called the self-resonant frequency (SRF). Lower distributed capacitances for a given inductance value will result in a higher SRF value for the inductor and vice versa. (see SRF)

### EMI

EMI is an acronym for Electromagnetic Interference. It is unwanted electrical energy in any form. EMI is often used interchangeably with "Noise".

## H - L

### Eddy Current Losses

Eddy current losses are present in both the magnetic core and winding of an inductor. Eddy currents in the winding (or conductor) contribute to two main types of losses: losses due to proximity effects and skin effects. As for the core losses, an electric field around the flux lines in the magnetic field is generated by alternating magnetic flux. This will result in eddy currents if the magnetic core material has electrical conductivity. Losses result from this phenomenon since the eddy currents flow in a plane that is perpendicular to the magnetic flux lines.

### Epoxy Coated Inductor

Inductors that have been coated with epoxy as opposed to having a molded case, shrink wrapped tubing or left with an open construction body. Epoxy coated inductors typically have smooth edges and surfaces. The epoxy coat acts as an insulation. Both radial and axial styles can be found with epoxy coated surfaces.

### Ferrite Core

Ferrite is a magnetic material which consists of a mixed oxide of iron and other elements that are made to have a crystalline molecular structure. The crystalline structure is created by firing the ferrite material at a very high temperature for a specified amount of time and profile. The general composition of ferrites is  $xxFe_2O_4$  where xx represents one or several metals. The most popular metal combinations are manganese and zinc (MnZn) and nickel and zinc (NiZn). These metals can be easily magnetized.

### Filter

A circuit or device whose purpose is to control electrical energy at a given frequency or over a range of frequencies. Groups of passive components are commonly used to construct many types of filters. These passive components include resistors, capacitors and inductors.

### Impedance

The impedance of an inductor is the total resistance to the flow of current, including the AC and DC component. The DC component of the impedance is simply the DC resistance of the winding. The AC component of the impedance includes the inductor reactance. The following formula calculates the inductive reactance of an ideal inductor (i.e., one with no losses) to a sinusoidal AC signal.

$$Z = X_L = 2\pi fL$$

L is in henries and f is in hertz. This equation indicates that higher impedance levels are achieved by higher inductance values or at higher frequencies. Skin effect and core losses also add to the impedance of an inductor. (see Skin Effect and Core Losses)

### Impedance Analyzer

Test instrument capable of measuring a wide range of impedance parameters, gain and phase angle. In testing inductors, impedance analyzers can measure inductance, Q, SRF, insertion loss, impedance and capacitance. They operate in a much more automatic fashion in comparison to Q Meters. Some impedance analyzers have a wider test frequency range than a Q meter.

### Incremental Current

The DC bias current flowing through the inductor which causes an inductance drop of 5% from the initial zero DC bias inductance value. This current level indicates where the inductance can be expected to drop significantly if the DC bias current is increased further. This applies mostly to ferrite cores in lieu of powdered iron. Powdered iron cores exhibit "soft" saturation characteristics. This means their inductance drop from higher DC levels is much more gradual than ferrite cores. The rate at which the inductance will drop is also a function of the core shape. (see Saturation Current)

## Inductance

The property of a circuit element which tends to oppose any change in the current flowing through it. The inductance for a given inductor is influenced by the core material, core shape and size, the turns count and the shape of the coil. Inductors most often have their inductances expressed in microhenries ( $\mu\text{H}$ ). The following table can be used to convert units of inductance to microhenries. Thus, 47 mH would equal 47,000  $\mu\text{H}$ .

1 henry (H) =  $10^6 \mu\text{H}$

1 millihenry (mH) =  $10^3 \mu\text{H}$

1 microhenry ( $\mu\text{H}$ ) = 1  $\mu\text{H}$

1 nanohenry (nH) =  $10^{-3} \mu\text{H}$

## Inductance Tolerance

Standard inductance tolerances are typically designated by a tolerance letter. Standard inductance tolerance letters include.

(see [Inductor Color Codes](#))

LETTER	TOLERANCE
F	$\pm 1\%$
G	$\pm 2\%$
H	$\pm 3\%$
J	$\pm 5\%$
K	$\pm 10\%$
L	$\pm 15\%$
M	$\pm 20\%$

\*  $L = \pm 20\%$  for some Military Products

## Input Line Filter

A power filter placed on the input to a circuit or assembly that attenuates noise introduced from the power bus. The filter is designed to reject noise within a frequency band. Typically these filters are low-pass filters meaning they pass low frequency signals such as the DC power and attenuate higher frequency signals which consist of mainly noise. Band pass or low pass filters are commonly made up of inductor and capacitor combinations. (also see Noise, Attenuation, EMI and PI-Filter)

## Inductor

A passive component designed to resist changes in current. Inductors are often referred to as “AC Resistors”. The ability to resist changes in current and the ability to store energy in its magnetic field, account for the bulk of the useful properties of inductors. Current passing through an inductor will produce a magnetic field. A changing magnetic field induces a voltage which opposes the field-producing current. This property of impeding changes of current is known as inductance. The voltage induced across an inductor by a change of current is defined as:

$$v(t) = L \frac{di(t)}{dt}$$

Thus, the induced voltage is proportional to the inductance value and the rate of current change. (see Inductance and more about Inductor)

## Kool Mu<sup>®</sup> Core

\* Kool Mu<sup>®</sup> is a magnetic material that has an inherent distributed air gap. The distributed air gap allows the core to store higher levels of magnetic flux when compared to other magnetic materials such as ferrites. This characteristic allows a higher DC current level to flow through the inductor before the inductor saturates. Kool Mu<sup>®</sup> material is an alloy that is made up of basically nickel and iron powder (approx. 50 % of each) and is available in several permeabilities. It has a higher permeability than powdered iron and also lower core losses. Kool Mu<sup>®</sup> is required to be pressed at a much higher pressure than powdered iron material. The manufacturing process includes an annealing step that relieves the pressure put onto the powdered metals which restores their desirable magnetic properties. Thus, the powdered particles require a high temperature insulation as compared to powdered iron. Kool Mu<sup>®</sup> performs well in power switching applications. The relative cost is significantly higher than powdered iron.

\* Kool Mu<sup>®</sup> is a registered trademark of Magnetics, Inc.

## M - O

### Laminated Cores

Cores constructed by stacking multiple laminations on top of each other. The laminations are offered in a variety of materials and thicknesses. Some laminations are made to have the grains oriented to minimize the core losses and give higher permeabilities. Each lamination has an insulated surface which is commonly an oxide finish. Laminated cores are used in some inductor designs but are more common in a wide variety of transformer applications.

### Litz Wire

Wire consisting of a number of separately insulated strands that are woven or bunched together such that each strand tends to take all possible positions in the cross section of the wire as a whole. The current through each individual strand is divided equally since this wire design equalizes the flux linkages and reactance of the individual strands. In other words, a Litz conductor has lower AC losses than comparable solid wire conductors which becomes important as the operating frequency increases. (see Skin Effect)

### Magnetic Wire

Wire used to create a magnetic field such as those in magnetic components (inductors and transformers). Magnet wire is nearly 100% copper and must be made from virgin copper. It is offered with a number of different organic polymer film coatings.

### Matched Impedance

The condition that exists when two coupled circuits are adjusted so that the output impedance of one circuit equals the input impedance of the other circuit connected to the first. There is a minimum power loss between two circuits when their connecting impedances are equal.

### Molded Inductor

An inductor whose case has been formed via a molding process. Common molding processes include injection and transfer molding. Molded inductors typically have well defined body dimensions which consist of smooth surfaces and sharper corners as compared to other case types such as epoxy coated and shrink wrap coatings. (see Inductor)

### Monolithic Inductor

(see Multilayer Inductor)

### Multilayer Inductor

An inductor constructed by layering the coil between layers of core material. The coil typically consists of a bare metal material (no insulation). This technology is sometimes referred to as “non-wirewound”. The inductance value can be made larger by adding additional layers for a given spiral pattern.

## MPP Core

MPP is an acronym for molypermalloy powder. It is a magnetic material that has an inherent distributed air gap. The distributed air gap allows the core to store higher levels of magnetic flux when compared to other magnetic materials such as ferrites. This characteristic allows a higher DC current level to flow through the inductor before the inductor saturates.

The basic raw materials are nickel, iron and molybdenum. The ratios are: approximately 80% nickel, 2% - 3% molybdenum, and the remaining is iron. The manufacturing process includes an annealing step as discussed in the Kool Mu<sup>®</sup> definition. MPP stores higher amounts of energy and has a higher permeability than Kool Mu<sup>®</sup>. Cores are offered in 10 or more permeability selections. The core characteristics allow inductors to perform very well in switching power applications. Since higher energy can be stored by the core, more DC current can be passed through the inductor before the core saturates. The cost of MPP is significantly higher than Kool Mu<sup>®</sup>, powdered irons and most ferrite cores with similar sizes. (see Saturation Current)

## Noise

Unwanted electrical energy in a circuit that is unrelated to the desired signal. Sources of noise are most often generated by some type of switching circuit. Common sources include switching voltage regulators and clocked signals such as digital circuits.

## Ohm

The unit of measurement for resistance and impedance. Resistance is calculated by Ohm's Law:

$$R = V/I$$

where R = resistance, V = voltage, I = current.

## Operating Temperature Range

Range of ambient temperatures over which a component can be operated safely. The operating temperature is different from the storage temperature in that it accounts for the component's self temperature rise caused by the winding loss from a given DC bias current. This power loss is referred to as the "copper" loss and is equal to:

$$Power\ Loss = (DCR)(I_{dc}^2)$$

This power loss results in an increase to the component temperature above the given ambient temperature. Thus, the maximum operating temperature will be less than the maximum storage temperature:

$$Maximum\ Operating\ Temperature = Storage\ Temperature - Self\ Temperature\ Rise$$

(see Core Losses)

**P - Q**

## Permeability (Core)

The permeability of a magnetic core is the characteristic that gives the core the ability to concentrate lines of magnetic flux. The core material, as well as the core geometry, affect the core's "effective permeability". For a given core shape, size and material, and a given winding, higher permeability magnetic materials result in higher inductance values as opposed to lower permeability materials.

## Phenolic Core

Phenolic is a common material used for inductor cores. Many are made of a polyester base that have high temperature characteristics. It is also common for phenolic cores to have high flammability ratings such as UL94V-0. Phenolic cores also provide high strength and are more economical than ceramic cores.

Phenolic has no magnetic properties. Thus, there is no increase in permeability due to the core material.

Phenolic core inductors are often referred to as "air core" inductors and are most often used in high frequency applications where low inductance values, very low core losses and high Q values are required.

## PI-Filter

A filter consisting of two capacitors connected in parallel with a series inductor. These filters are commonly found near DC-DC converters to filter ripple current and voltage.

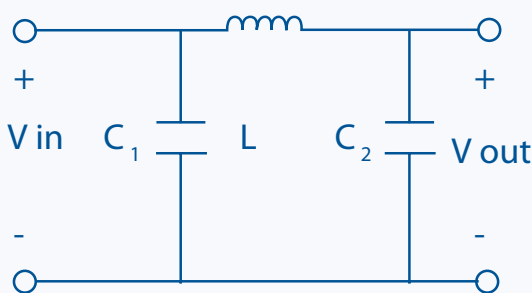

**Basic PI-Filter**

## Polyolefin Tubing

A common shrink wrap (tubing) used in the electronic industry. It is often used to provide insulation or protect wire insulation such as coil windings. Polyolefin tubing is a polymer which can be provided to meet various degrees of flammability requirements.

## Powered Iron Core

Powdered iron is a magnetic material that has an inherent distributed air gap. The distributed air gap allows the core to store higher levels of magnetic flux when compared to other magnetic materials such as ferrites. This characteristic allows a higher DC current level to flow through the inductor before the inductor saturates.

Powdered iron cores are made of nearly 100% iron. The iron particles are insulated from each other, mixed with a binder (such as phenolic or epoxy) and pressed into the final core shape. The cores are cured via a baking process. Other characteristics of powdered iron cores include: they are typically the lowest cost alternative and their permeabilities typically have a more stable temperature coefficient than ferrites. (see Saturation Current)

## Q Meter

A standard instrument used to measure the inductance and Q of small RF inductors. The Q meter is based on a stable, continuously variable oscillator and a resonant circuit which is connected to the part to be tested.

The Q is proportional to the voltage across the internal calibrated variable capacitor. The voltage is measured by an internal RF voltmeter. The capable test frequency range is near 22 kHz to 70 MHz.

▶ R - S

## Q Factor

The Q value of an inductor is a measure of the relative losses in an inductor. The Q is also known as the “quality factor” and is technically defined as the ratio of inductive reactance to effective resistance, and is represented by:

$$Q = \frac{X_L}{R_e} = \frac{2\pi fL}{R_e}$$

Since  $X_L$  and  $R_e$  are functions of frequency, the test frequency must be given when specifying Q.  $X_L$  typically increases with frequency at a faster rate than  $R_e$  at lower frequencies, and vice versa at higher frequencies. This results in a bell-shaped curve for Q vs frequency.  $R_e$  is mainly comprised of the DC resistance of the wire, the core losses and skin effect of the wire. Based on the above formula, it can be shown that the Q is zero at the self-resonant frequency since the inductance is zero at this point.

## RF Choke

Another name for a radio frequency inductor which is intended to filter or choke out signals. (see Inductor)

## RFI

RFI is an acronym for Radio-Frequency Interference. It is an older and more restrictive term that is used interchangeably with “EMI”. (see EMI)

## Radial Inductor

An inductor constructed on a core with leads exiting from the same side of the inductor body as to be mounted in the same plane. Radial inductors most often refer to two lead devices but technically include devices with more than two leads as well. Some common core shapes include rod cores, bobbins and toroids. (see Inductor)

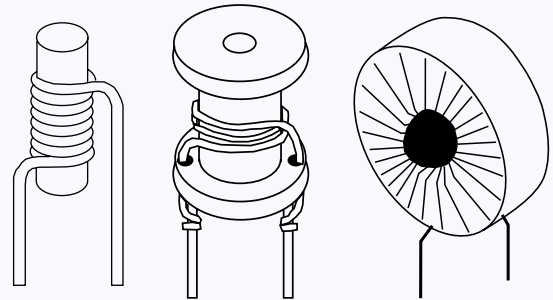

Radial Inductor Styles

## Ripple Voltage

The periodic alternating voltage imposed on the voltage output of a switching voltage converter. The ripple voltage is normally specified as a peak-to-peak value.

## Rated Current

The level of continuous DC current that can be passed through the inductor. This DC current level is based on a maximum temperature rise of the inductor at the maximum rated ambient temperature. The rated current is related to the inductor's ability to minimize the power losses in the winding by having a low DC resistance. It is also related to the inductor's ability to dissipate this power lost in the windings. Thus, the rated current can be increased by reducing the DC resistance or increasing the inductor size.

For low frequency current waveforms, the RMS current can be substituted for the DC rated current. The rated current is not related to the magnetic properties of the inductor. (see Incremental Current and Saturation Current)

## Reactance

The imaginary part of the impedance. (see Impedance)

## Saturation Current

The DC bias current flowing through the inductor which causes the inductance to drop by a specified amount from the initial zero DC bias inductance value. Common specified inductance drop percentages include 10% and 20%. It is useful to use the 10% inductance drop value for ferrite cores and 20% for powdered iron cores in energy storage applications.

The cause of the inductance to drop due to the DC bias current is related to the magnetic properties of the core. The core, and some of the space around the core, can only store a given amount of magnetic flux density.

Beyond the maximum flux density point, the permeability of the core is reduced. Thus, the inductance is caused to drop. Core saturation does not apply to "air-core" inductors. (see Incremental Current and Permeability)

## SRF (Self-Resonant Frequency)

The frequency at which the inductor's distributed capacitance resonates with the inductance. It is at this frequency that the inductance is equal to the capacitance and they cancel each other. The inductor will act purely resistive with a high impedance at the SRF point.

The distributed capacitance is caused by the turns of wire layered on top of each other and around the core. This capacitance is in parallel to the inductance. At frequencies above the SRF, the capacitive reactance of the parallel combination will become the dominant component.

Also, the Q of the inductor is equal to zero at the SRF point since the inductive reactance is zero. The SRF is specified in MHz and is listed as a minimum value on product data sheets. (also see Distributed Capacitance)

## Shielded Inductor

An inductor designed for its core to contain a majority of its magnetic field. Some inductor designs are self shielding. Examples of these are magnetic core shapes which include toroids, pot cores and E-cores. Magnetic core shapes such as slug cores and bobbins require the application of a magnetic sleeve or similar method to yield a shielded inductor.

It should be noted that magnetic shielding is a matter of degree. A certain percentage of the magnetic field will escape the core material. This is even applicable for toroidal cores as lower core permeabilities will have higher fringing fields than will high permeability toroidal cores. (see Closed Magnetic Path)

▶ T - Z

## Skin Effect

Skin effect is the tendency for alternating current to flow near the surface of the conductor in lieu of flowing in a manner as to utilize the entire cross-sectional area of the conductor. This phenomenon causes the resistance of the conductor to increase. The magnetic field associated with the current in the conductor causes eddy currents near the center of the conductor which opposes the flow of the main current near the center of the conductor. The main current flow is forced further to the surface as the frequency of the alternating current increases. (see Litz Wire)

## Slug Core

A core with the shape of a cylindrical rod. Slug cores typically refer to cores with no leads. Axial leaded slug cores are very common. Non-leaded slug cores are typically used in power filtering applications. They exhibit higher flux density characteristics than other core shapes as most of the magnetic energy is stored in the air around the core. (see Axial Inductors and Radial Inductors)

## Storage Temperature Range

Range of ambient temperatures over which a component can be stored safely. (see Operating Temperature Range)

## Switching Frequency

The operating frequency of a switching regulator.

## Switching Regulator

A circuit that is designed to regulate the output voltage, from a given input voltage, by using a closed control loop design. The most common switching regulator types involve a magnetic component, such as an inductor or transformer, that is used to store and transfer energy to the output by having the current switched on and off. (see Boost Regulator and Buck Regulator)

## Tape Wound Cores

Cores made by rolling strips of alloy iron into a toroidal shape. The metal strips have a precisely controlled thickness which are coated with a very thin insulation material to prevent the metal in the layers to make contact with each other. The finished cores have an outside coating to protect the metal layers and they are offered in a variety of material mixes. Tape wound cores are capable of storing high amounts of energy and contain a high permeability. Their major disadvantage is that they are relatively expensive when compared to other core types. (see Toroidal Inductor)

## Temperature Rise

The increase in surface temperature of a component in air due to the power dissipation in the component. The power dissipation for an inductor includes both copper and core losses.

## Toroidal Inductor

An inductor constructed by placing a winding(s) on a core that has a donut shaped surface. Toroidal cores are available in many magnetic core materials within the four basic types: Ferrite, Powdered Iron, Alloy and High Flux and Tape Wound. Characteristics of toroidal inductors include: self shielding (closed magnetic path), efficient energy transfer, high coupling between windings and early saturation.

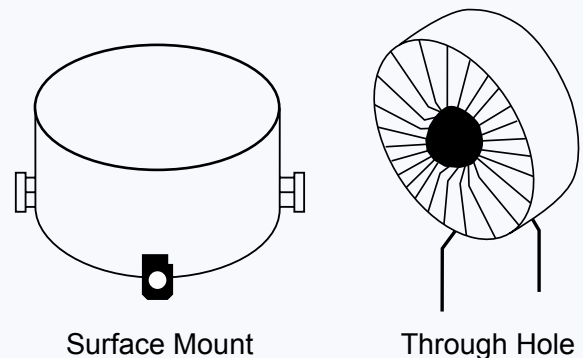

## Test Frequency

The frequency at which inductors are tested for either inductance or Q or both. Some test frequencies used widely in the industry include:

COMMON TEST FREQUENCIES	
TEST FREQUENCY	INDUCTOR/VALUE MEASURED
1 KHz	Power Inductors (Wide Value Range)
0.079 MHz	RF Inductors (above 10 000 $\mu$ H to 100 000 $\mu$ H)
0.250 MHz	RF Inductors (above 1000 $\mu$ H to 10 000 $\mu$ H)
0.790 MHz	RF Inductors (above 100 $\mu$ H to 1000 $\mu$ H)
2.5 MHz	RF Inductors (above 10 $\mu$ H to 100 $\mu$ H)
7.9 MHz	RF Inductors (above 1 $\mu$ H to 10 $\mu$ H)
25 MHz	RF Inductors (above 0.10 $\mu$ H to 1 $\mu$ H)
50 MHz	RF Inductors (0.01 $\mu$ H to 0.1 $\mu$ H)

Most of these test frequencies have been designated by military specifications. However, there are some conflicting frequency assignments among the military specifications. There is a present trend to assign test frequencies that match the user frequencies. This is particularly true for very low values. These user frequencies do not match those listed above.

## Volt Microsecond Constant

The product of the voltage applied across the winding and the time for the magnetizing current to reach 1.5 times the linear extrapolation of the current waveform. This constant is a measure of the energy handling capability of a transformer or inductor. It is dependent upon the core area, core material (including the saturation flux density of the core), the number of turns of the winding and the duty cycle of the applied pulse.

## Volume Resistivity (Core)

The ability of a core to resist the flow of electrical current either through the bulk of the material or on its surface. The unit of the volume resistivity is Ohm - cm.

Core volume resistivity becomes an issue in inductor designs where the leads/terminals come in contact with the core material. This type includes axial and radial inductors that have leads epoxied into the core. As for core materials, high permeability ferrites present the most concern as their volume resistivity is typically the lowest.

Under certain conditions, a low resistive path can be realized between two inductor terminals if they are in contact with a low resistivity core. The inductor, under these conditions, will lose its higher impedance characteristics.

*[Back to 1st Page - What is an Inductor](#)*